



PROPOSED STORE FRONTS

The Wesleyan Building

581 BOYLSTON STREET

APRIL 12th, 2023



CHEVRON
PARTNERS

FINEGOLD ALEXANDER
ARCHITECTS



CONTEXT



Scope of New Retail Storefront



EXISTING CONDITIONS PHOTOS



EXISTING CONDITIONS PHOTOS



HISTORIC STOREFRONT CONDITION

ORIGINAL PEDIMENT DETAIL



MISSING DECORATIVE STONE







AREA STUDY

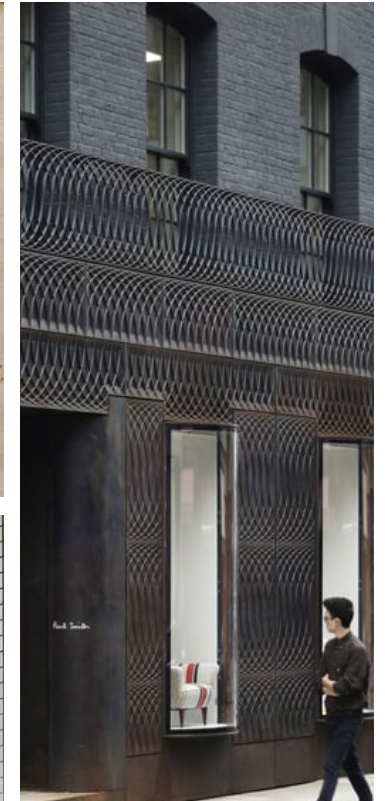

INSPIRATIONAL IMAGES



PROPOSED DEMOLITION

- == Remove Existing Wood or Metal Stud Wall and Associated Fasteners
 Existing Door to Remain
 Remove Existing Door, Frame, Hardware and Associated Accessories, Fittings, and Trim
 Remove Existing Windows, Associated Accessories, Fittings and Trim. Leave Masonry openings Free and Clear for New Work
 Existing Wall to Remain
 Remove Existing Assembly

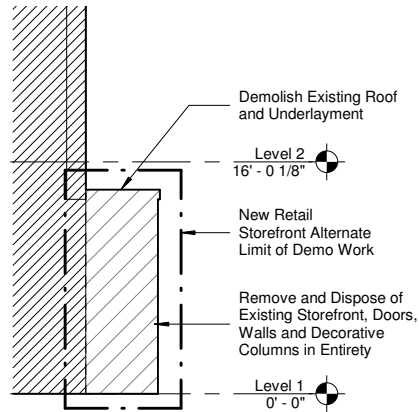

PROPOSED DEMO ELEVATION (WEST)

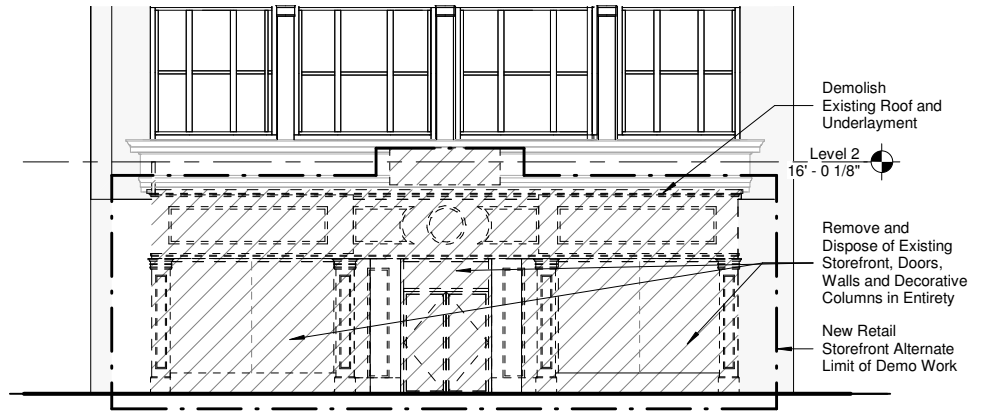

PROPOSED DEMO ELEVATION (SOUTH)

DEMO KEY

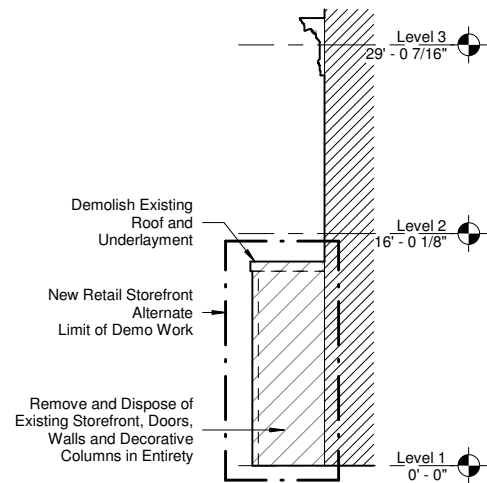

PROPOSED DEMO ELEVATION (EAST)

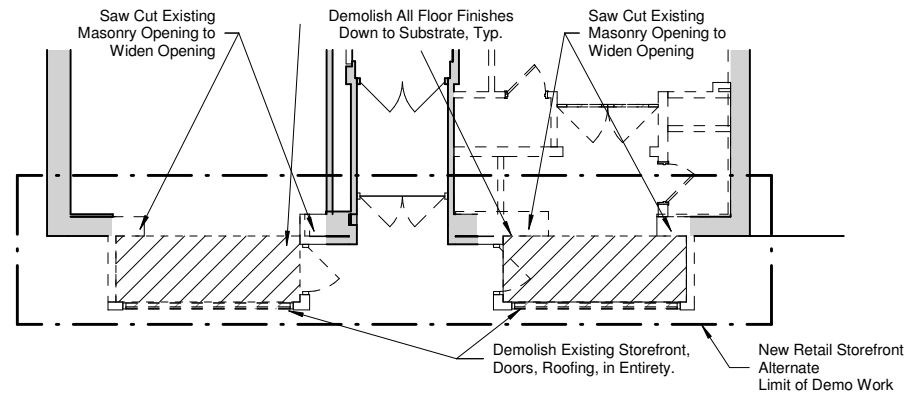

PROPOSED DEMO PLAN

EXISTING AND PROPOSED ELEVATIONS

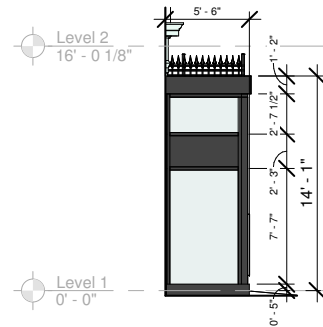

PROPOSED WEST ELEVATION

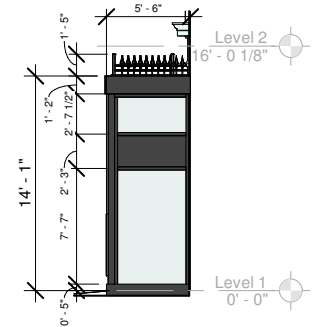

PROPOSED EAST ELEVATION

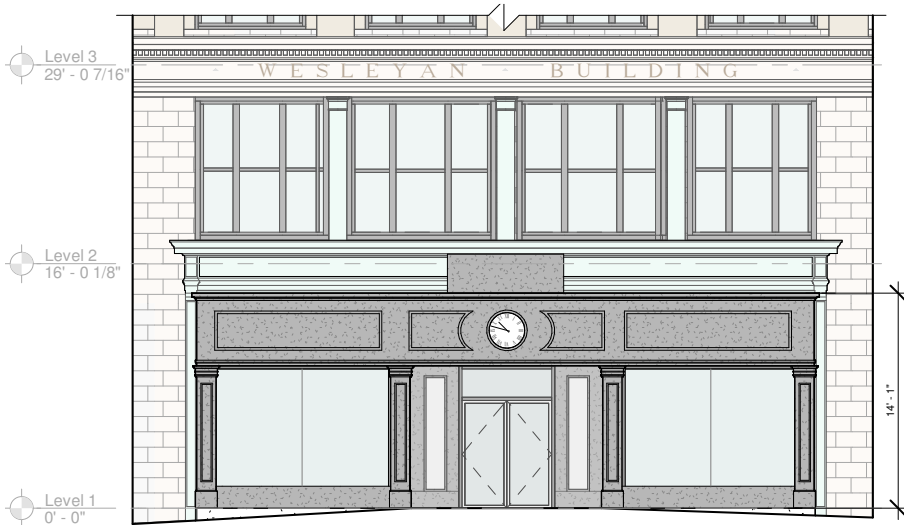

EXISTING FACADE ELEVATION

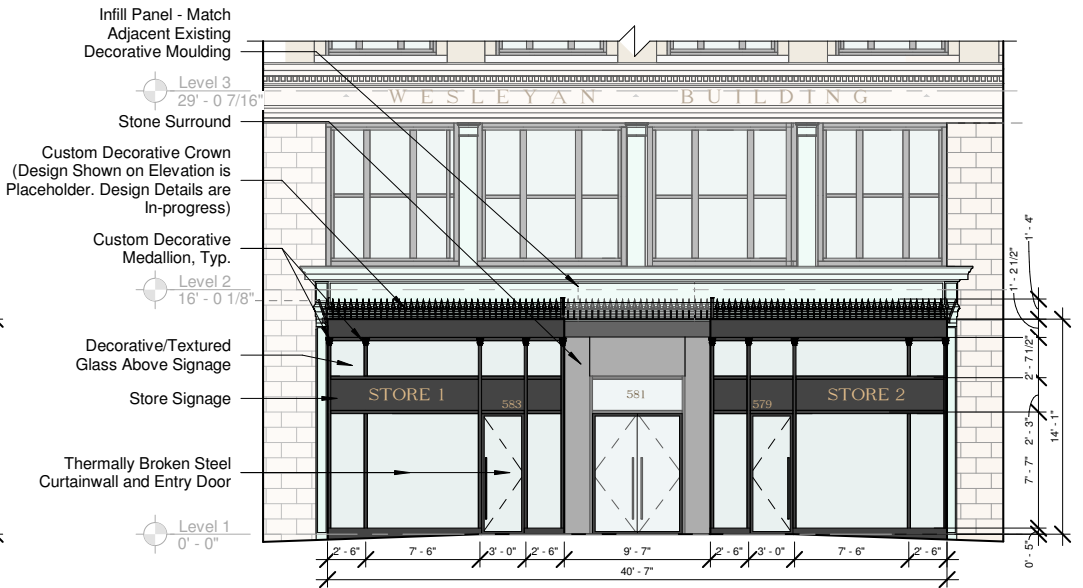

PROPOSED FACADE ELEVATION

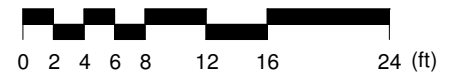

EXISTING AND PROPOSED PLANS

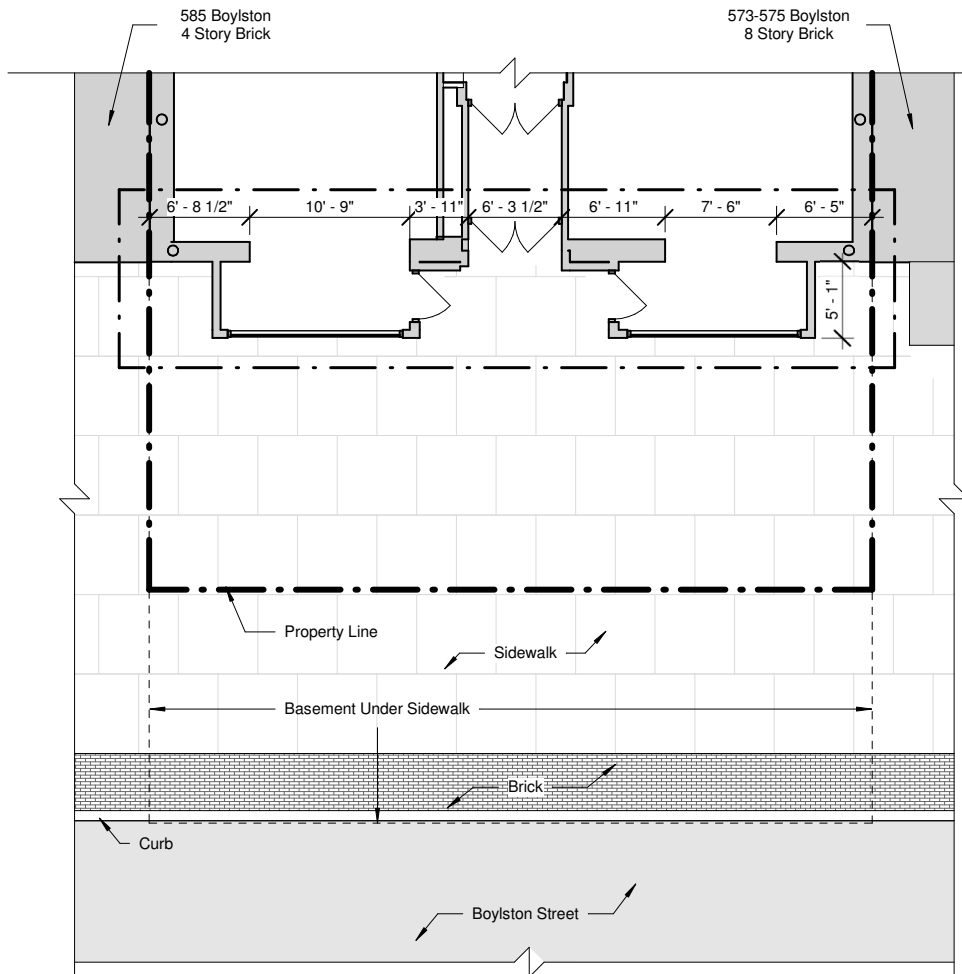

EXISTING PARTIAL FIRST LEVEL PLAN

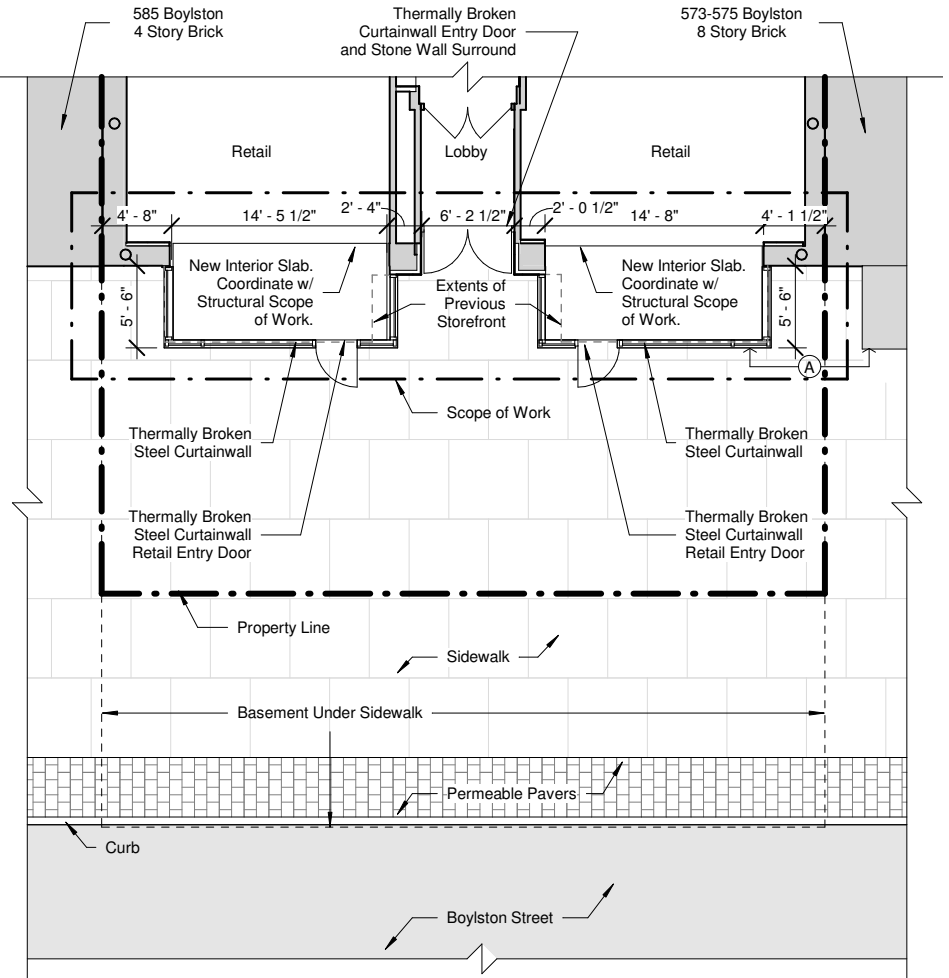

PROPOSED PARTIAL FIRST LEVEL PLAN

PROPOSED DETAILS

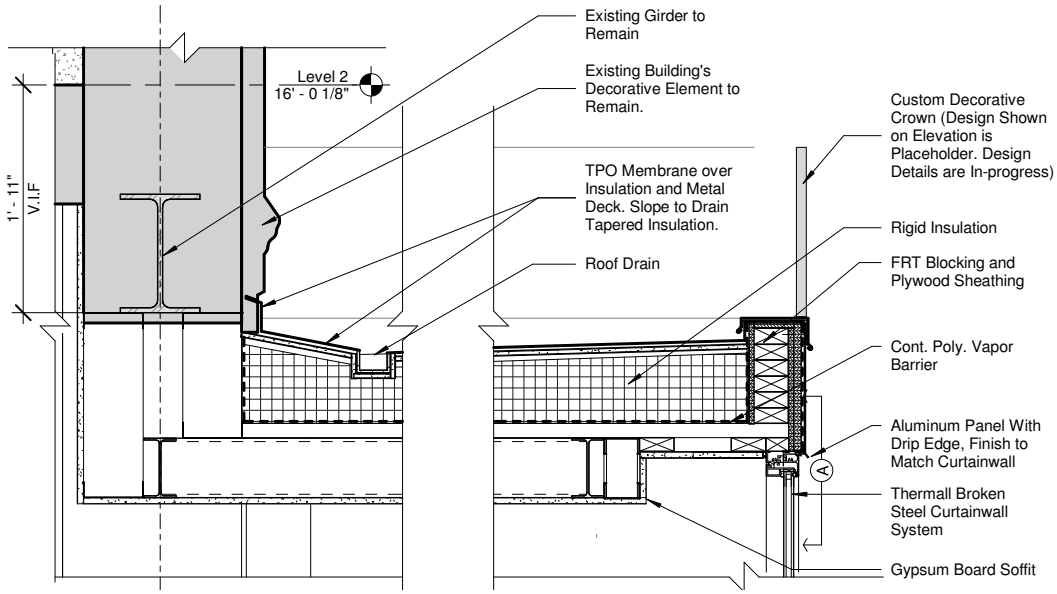

3. PROPOSED ROOF DETAIL

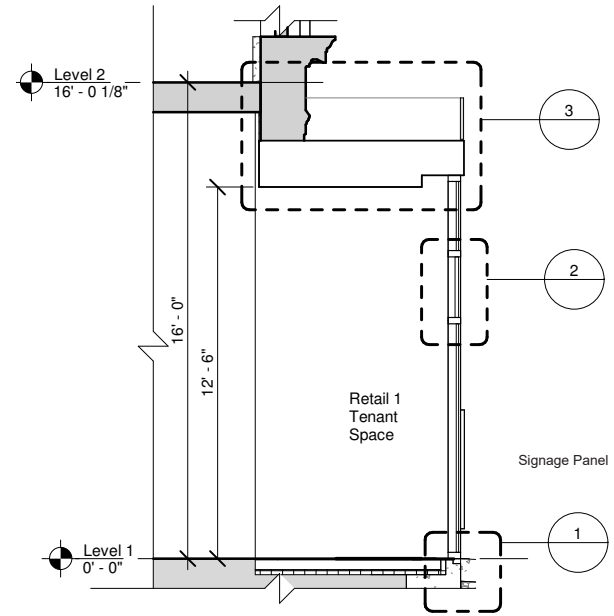

PROPOSED FACADE SECTION

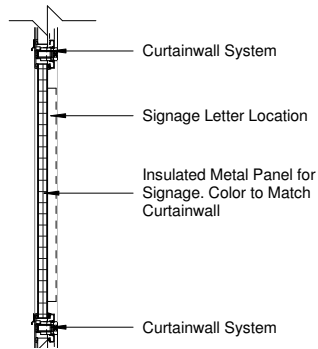

2. PROPOSED SIGNAGE PANEL DETAIL

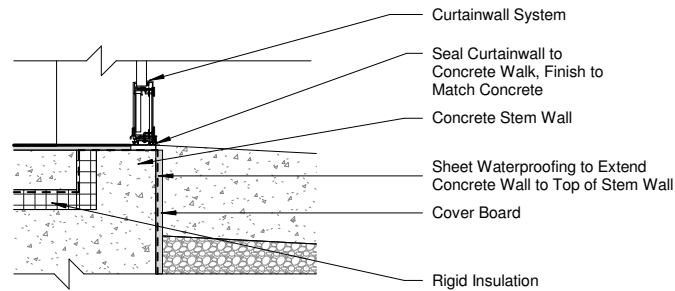

1. PROPOSED SILL DETAIL



PROPOSED MATERIALS

GLAZING



DECORATIVE METAL



MARBLE / STONE

