

CONNECT DOWNTOWN: PUBLIC GARDEN CROSSINGS

*Back Bay Architectural District Commission
November 10, 2021*

CONNECT DOWNTOWN

Project goals:

- ▶ Improve pedestrian crossings along the route,
- ▶ Provide comfortable, reasonably direct routes for bicyclists, and
- ▶ Enhance pedestrian access to the Public Garden and Common.

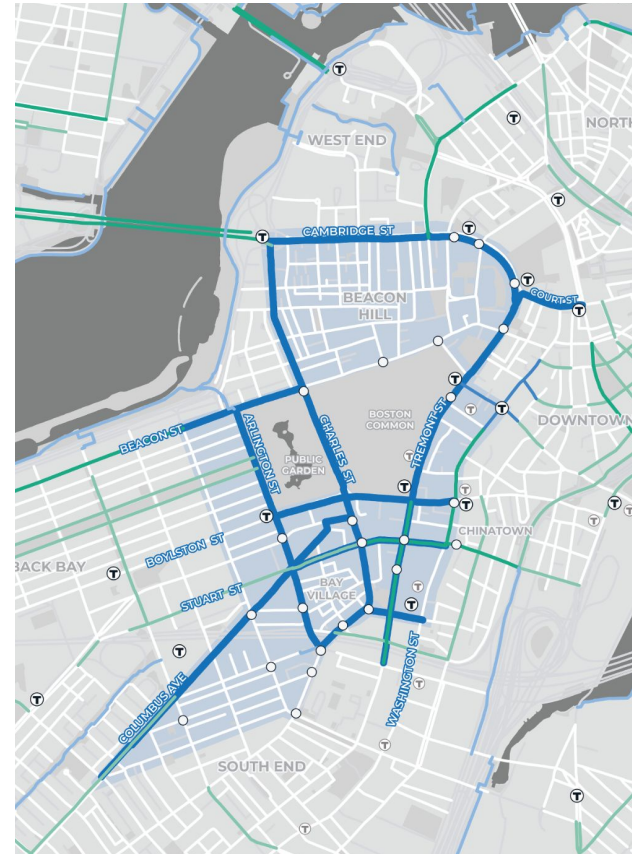



1

2

3

1. BEACON/ARLINGTON/MUGAR



Replace with concrete

Replace with brick

New directional
crosswalks and ramps

1. BEACON/ARLINGTON/MUGAR

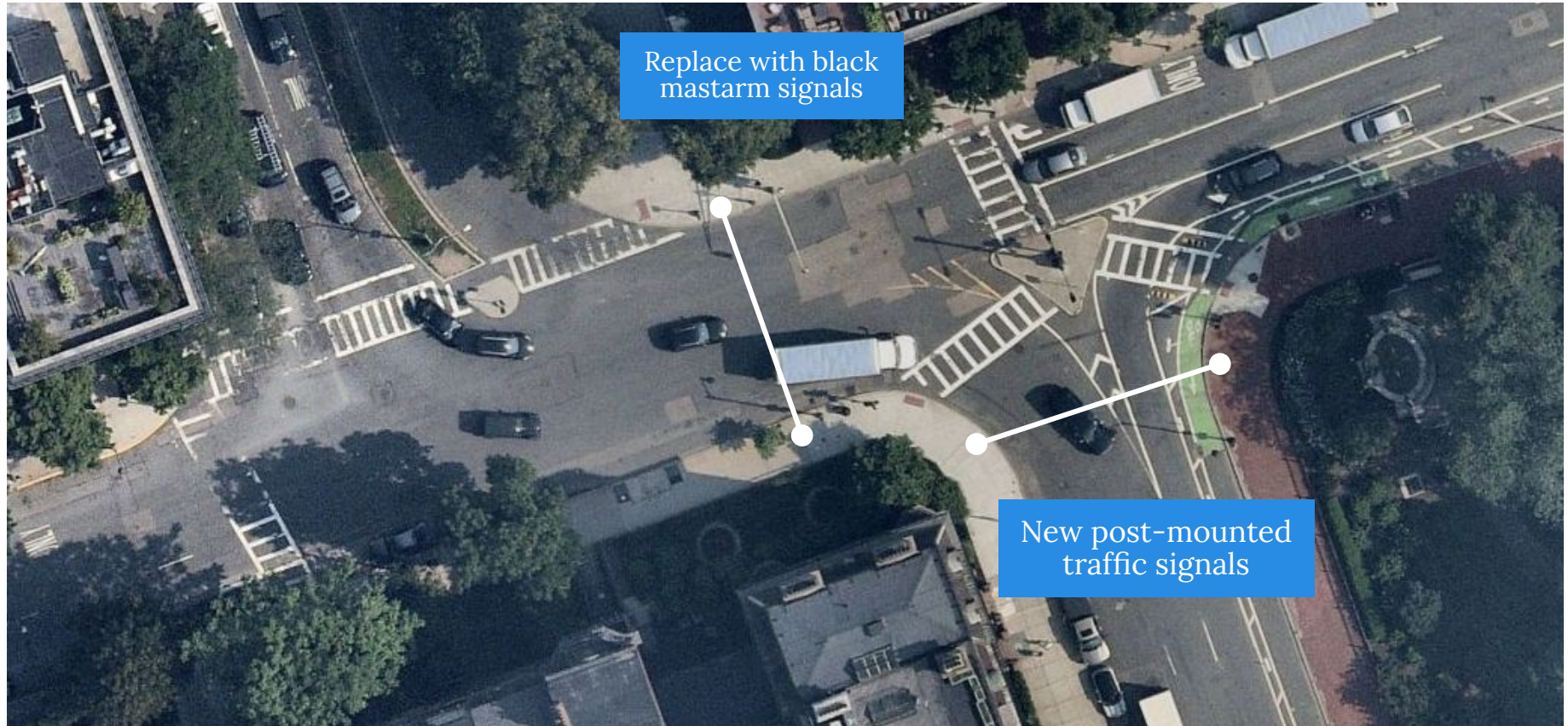

Replace with black mastarm signals

New post-mounted traffic signals

1. BEACON/ARLINGTON/MUGAR





1

2

3

2. ARLINGTON/COMM

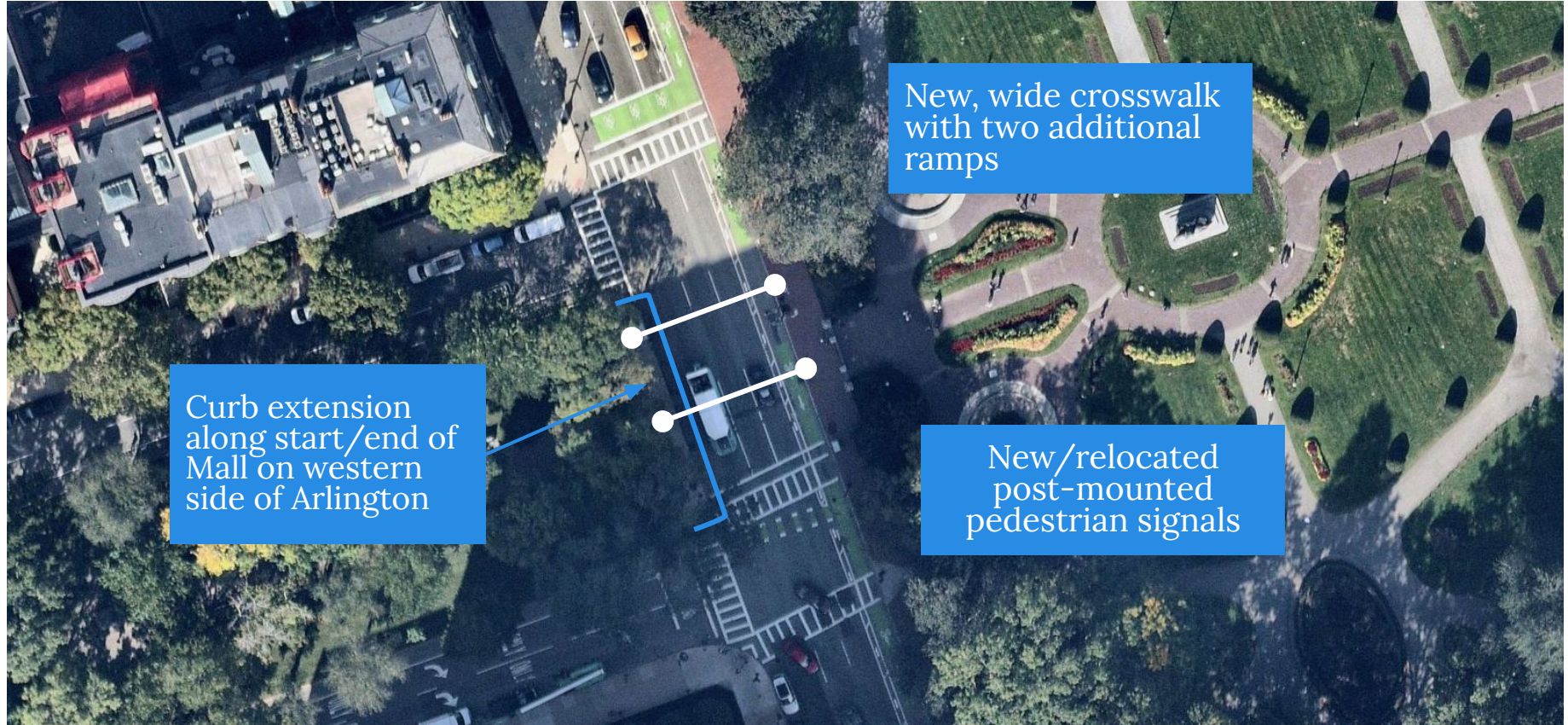

Curb extension along start/end of Mall on western side of Arlington

New, wide crosswalk with two additional ramps

New/relocated post-mounted pedestrian signals

2. ARLINGTON/COMM

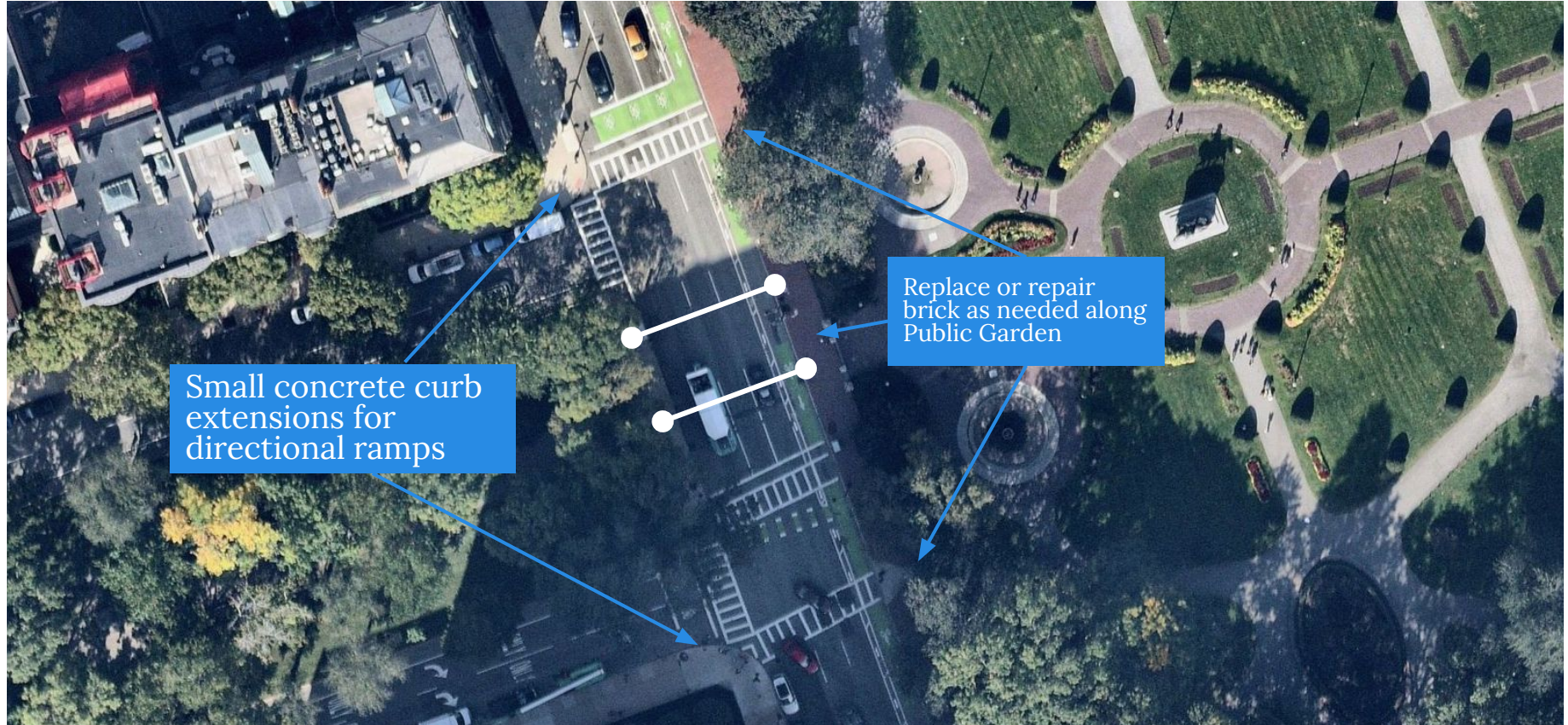

Small concrete curb extensions for directional ramps

Replace or repair brick as needed along Public Garden



1

2

3

3. ARLINGTON/BOYLSTON

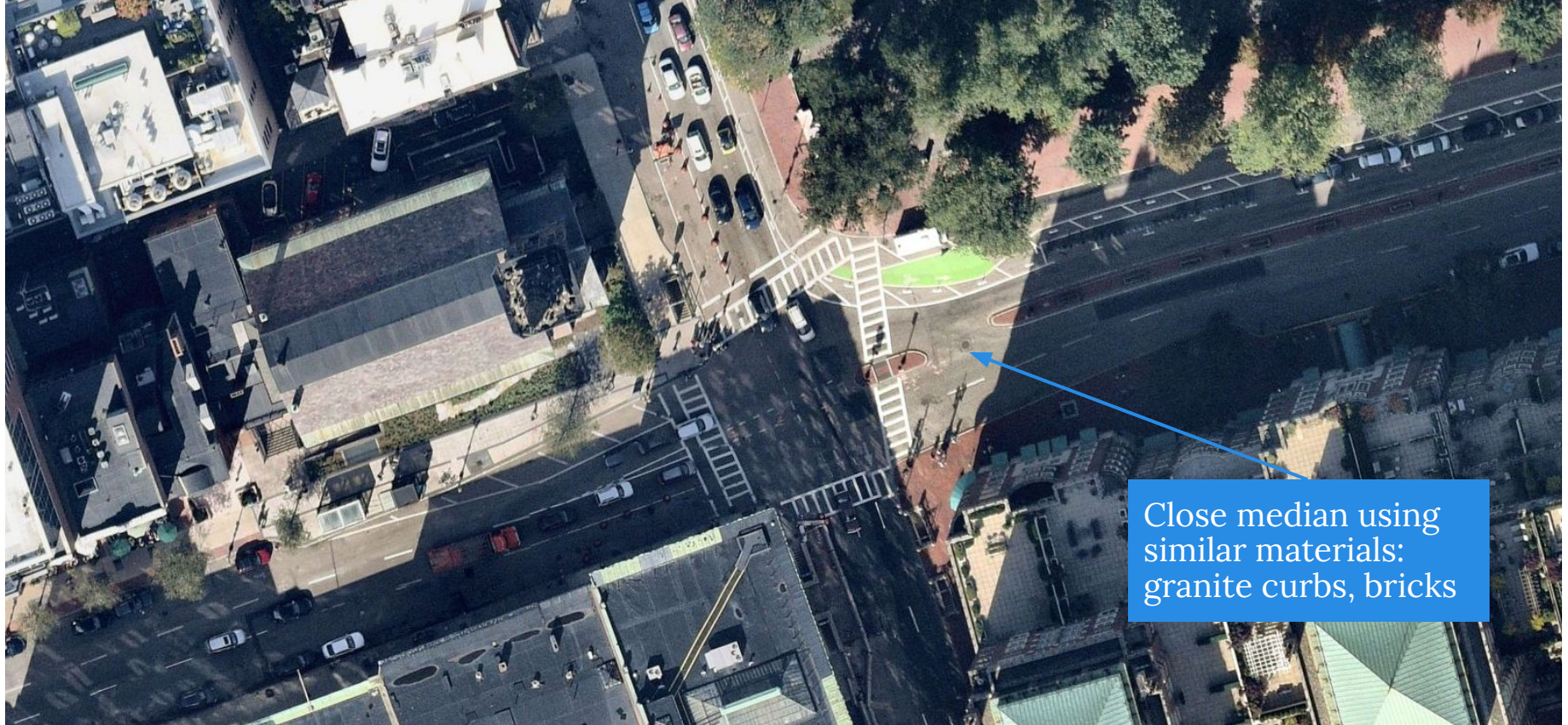

Close median using similar materials: granite curbs, bricks

MATERIALS: SIDEWALKS AND RAMPS



MATERIALS: STREET FURNITURE



BUILT ISLANDS: DESIGN APPROACH

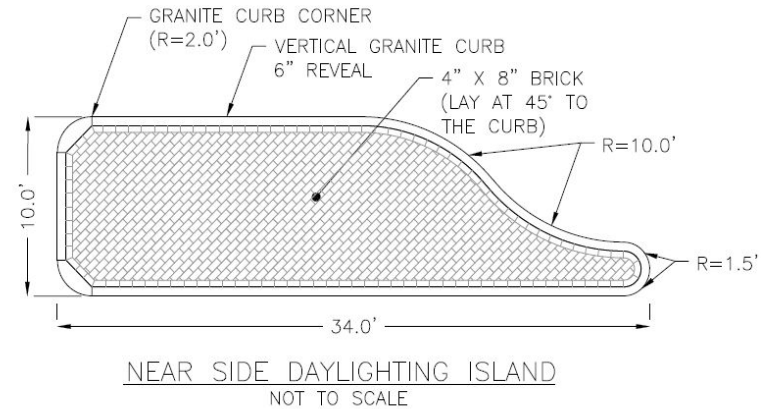
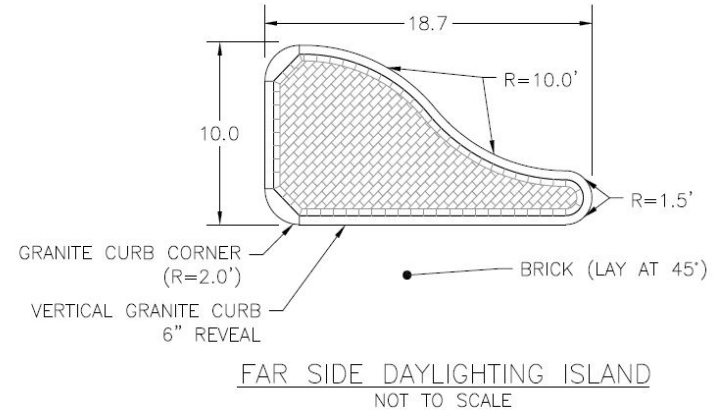

Note: This illustrates our proposed typical approach. We do not have formal designs for these crossings yet.