

LEGEND

- — — — — EDGE OF PAVEMENT
- x-x-x- CHAIN LINK FENCE
- x-x-x- WIRE FENCE
- WOOD FENCE
- 86.75
86.25 CURB WITH TOP AND BOTTOM CURB ELEVATION
- 12" RCP SEWERLINE & MANHOLE WITH PIPE SIZE, MATERIAL & FLOW DIRECTION
- 12" RCP DRAINLINE WITH PIPE SIZE, MATERIAL & FLOW DIRECTION, CATCHBASIN, MANHOLE & ROUND CATCHBASIN
- 6" CI WATER MANHOLE, WATER MAIN WITH SIZE, TEE, GATE VALVE & FIRE HYDRANT
- 10" DI GAS MAIN WITH SIZE & GATE VALVE
- #181 OHW EXISTING UTILITY POLE WITH DESIGNATION OVERHEAD WIRES AND GUY POLE
- E ELECTRIC MANHOLE & UNDERGROUND ELECTRIC LINES
- T TELEPHONE MANHOLE & UNDERGROUND TELEPHONE LINES
- RETAINING WALL
- × 100.7 SPOT ELEVATION
- 93.7
12" M PROMINENT DECIDUOUS TREE WITH ELEVATION, SIZE AND SPECIES
- ☆ LIGHT POLE
- RCP REINFORCED CONCRETE PIPE
- CICL CAST IRON CEMENT LINED
- CPP CORRUGATED PLASTIC PIPE
- PVC POLYVINYL CHLORIDE
- VC VITRIFIED CLAY
- SL SOUTHERN LOW WATER SERVICE
- SMH SEWER MANHOLE
- DMH DRAIN MANHOLE
- CB CATCH BASIN
- RCB ROUND CATCH BASIN
- BOLLARD
- SIGN
- MANHOLE (UNKNOWN UTILITY)
- (R) RECORD
- (C) CALCULATED
- (R/H) RECORD AND HELD
- VGC VERTICAL GRANITE CURB
- BIT. CONC. BITUMINOUS CONCRETE
- S.B. STONE BASE

NOTES:

- 1) ELEVATIONS SHOWN HEREON REFER TO BOSTON CITY BASE PROJECT BENCH MARK IS THE RIGHT OUTSIDE CORNER OF THE LOWEST STONE STEP AT #8 COLUMBUS SQUARE. ELEVATION IS 18.771 (B.C.B.).
- 2) UNDERGROUND UTILITIES SHOWN HEREON ARE COMPILED FROM FIELD LOCATIONS OF STRUCTURES AND FROM AVAILABLE RECORD INFORMATION ON FILE AT THE TOWN ENGINEERING OFFICES, TOWN D.P.W., MASS HIGHWAY DEPT. AND UTILITY COMPANIES. OTHER UNDERGROUND UTILITIES MAY EXIST. IT SHALL BE THE RESPONSIBILITY OF THE DESIGN ENGINEER AND THE CONTRACTOR TO VERIFY THE LOCATION, SIZE & ELEVATION OF ALL UTILITIES WITHIN THE AREA OF PROPOSED WORK AND TO CONTACT "DIG-SAFE" AT 811 AT LEAST 72 HOURS PRIOR TO ANY EXCAVATION, DEMOLITION OR CONSTRUCTION.
- 3) SEWER STRUCTURES WERE NOT OPENED AT THE TIME OF THE SURVEY DUE TO THE CURRENT HEALTH CRISIS.
- 4) THIS PLAN IS THE RESULT OF AN ON-THE-GROUND INSTRUMENT SURVEY CONDUCTED BY HANCOCK ASSOCIATES IN APRIL 2020.

ASSESSORS:

PARCEL ID: 0402838000

REFERENCES:

DEED BOOK 55579, PAGE 161
 PLAN BOOK 887, PAGE 170
 CITY NOTEBOOK: 607, PAGES 126-127
 663, PAGE 40
 890, PAGES 21-22
 CITY LAYOUT L-354
 STREET LINE MAP SHEET S-4
 BY: YUNITS ENGINEERING
 B.R.A. SOUTH END PROJECT R-56

RECORD OWNER:

APEIRON PROPERTIES, LLC
 197 WEST SPRINGFIELD STREET
 BOSTON, MA. 02118

ZONING:

SOUTH END NEIGHBORHOOD
 MFR - MULTIFAMILY RESIDENTIAL

#7
COLUMBUS SQUARE

Danvers, Massachusetts 01923

PREPARED FOR:

APEIRON PROPERTIES, LLC

197 West Springfield Street
 Boston, Massachusetts 02118

HANCOCK ASSOCIATES

Civil Engineers
 Land Surveyors
 Wetland Scientists

121 EAST BERKELEY STREET, BOSTON, MA 02118
 VOICE (617) 357-8145, FAX (617) 357-9495
 WWW.HANCOCKASSOCIATES.COM



NO.	BY	APP	DATE	ISSUE/REVISION	DESCRIPTION

DATE: 4/22/20 DRAWN BY: JML
 SCALE: 1"=5' CHECK BY: JAE

**EXISTING CONDITIONS
 PLAN OF LAND
 IN
 BOSTON, MA**

PLOT DATE: May 26, 2020 7:58 am
 PATH: C:\GIS\20 Projects\23451 - Apeiron - South End\DWG\

DWG: 23451ec.dwg

LAYOUT: EC

SHEET: 1 OF 1

PROJECT NO.:

23451

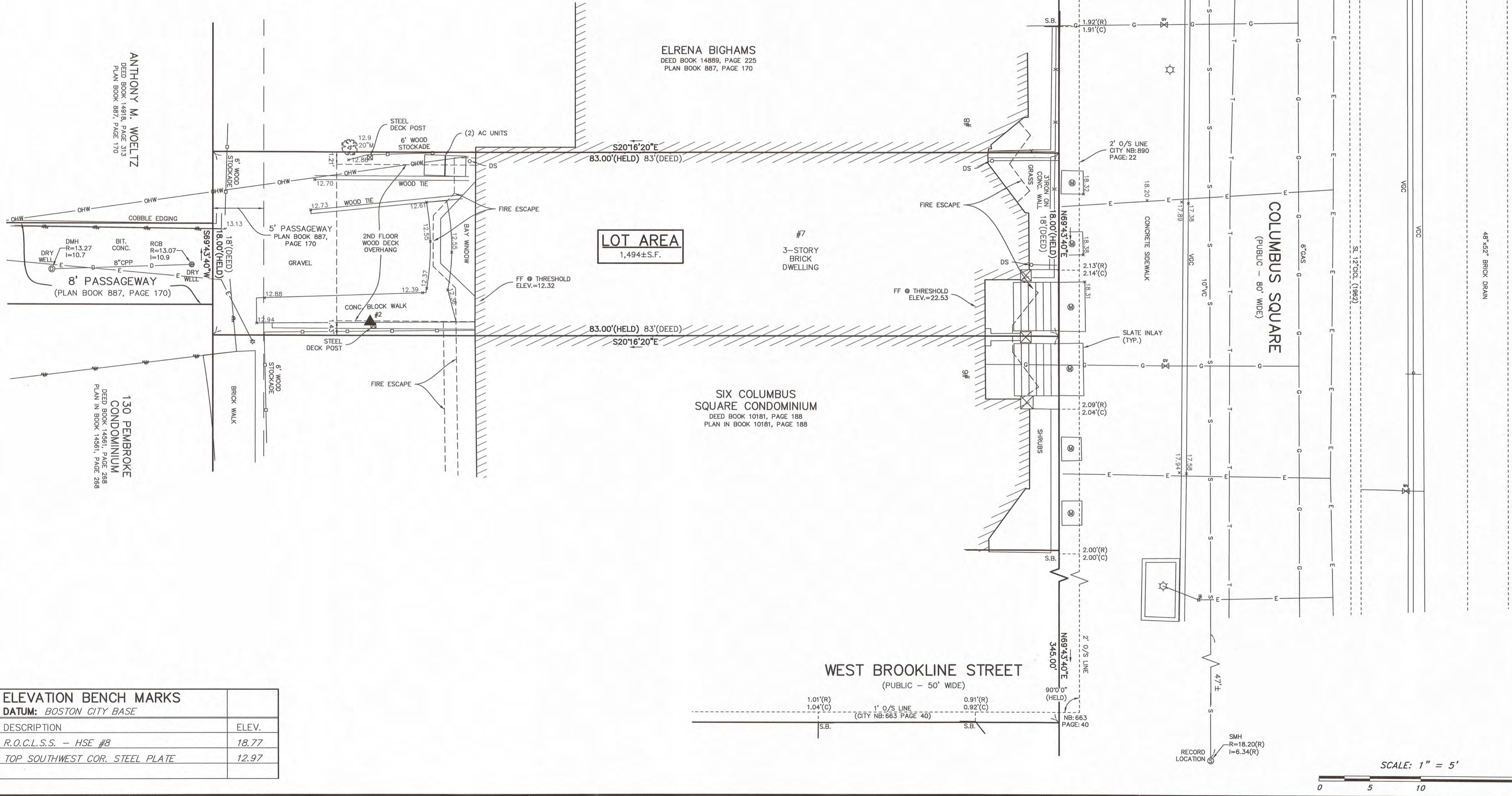

ELEVATION BENCH MARKS		
DATUM: BOSTON CITY BASE		
NO.	DESCRIPTION	ELEV.
1.	R.O.C.L.S.S. - HSE #8	18.77
2.	TOP SOUTHWEST COR. STEEL PLATE	12.97
3.		

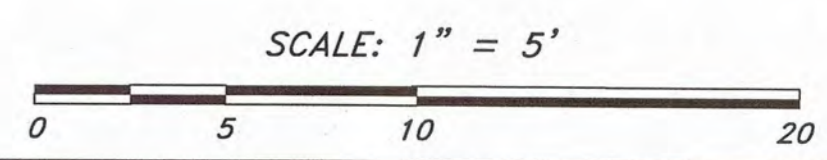

LEGEND

- — — — — EDGE OF PAVEMENT
- x-x-x-x- CHAIN LINK FENCE
- x-x-x-x- WIRE FENCE
- o-o-o-o- WOOD FENCE
- 86.75
x
86.25 CURB WITH TOP AND BOTTOM CURB ELEVATION
- S S 8" CI SEWERLINE & MANHOLE WITH PIPE SIZE, MATERIAL & FLOW DIRECTION
- D 12" RCP DRAINLINE WITH PIPE SIZE, MATERIAL & FLOW DIRECTION, CATCHBASIN, MANHOLE & ROUND CATCHBASIN
- W 6" CI WATER MANHOLE, WATER MAIN WITH SIZE, TEE, GATE VALVE & FIRE HYDRANT
- G 10" DI GAS MAIN WITH SIZE & GATE VALVE
- #181 OHW EXISTING UTILITY POLE WITH DESIGNATION OVERHEAD WIRES AND GUY POLE
- E ELECTRIC MANHOLE & UNDERGROUND ELECTRIC LINES
- T TELEPHONE MANHOLE & UNDERGROUND TELEPHONE LINES
- RETAINING WALL
- x 100.7 SPOT ELEVATION
- 93.7
12" M PROMINENT DECIDUOUS TREE WITH ELEVATION, SIZE AND SPECIES
- * LIGHT POLE
- RCP REINFORCED CONCRETE PIPE
- CIL CAST IRON CEMENT LINED
- CPP CORRUGATED PLASTIC PIPE
- PVC POLYVINYL CHLORIDE
- VC VITRIFIED CLAY
- SL SOUTHERN LOW WATER SERVICE
- SMH SEWER MANHOLE
- DMH DRAIN MANHOLE
- CB CATCH BASIN
- RCB ROUND CATCH BASIN
- BOLLARD
- SIGN
- MANHOLE (UNKNOWN UTILITY)
- (R) RECORD
- (C) CALCULATED
- (R/H) RECORD AND HELD
- VGC VERTICAL GRANITE CURB
- BIT. CONC. BITUMINOUS CONCRETE
- S.B. STONE BASE

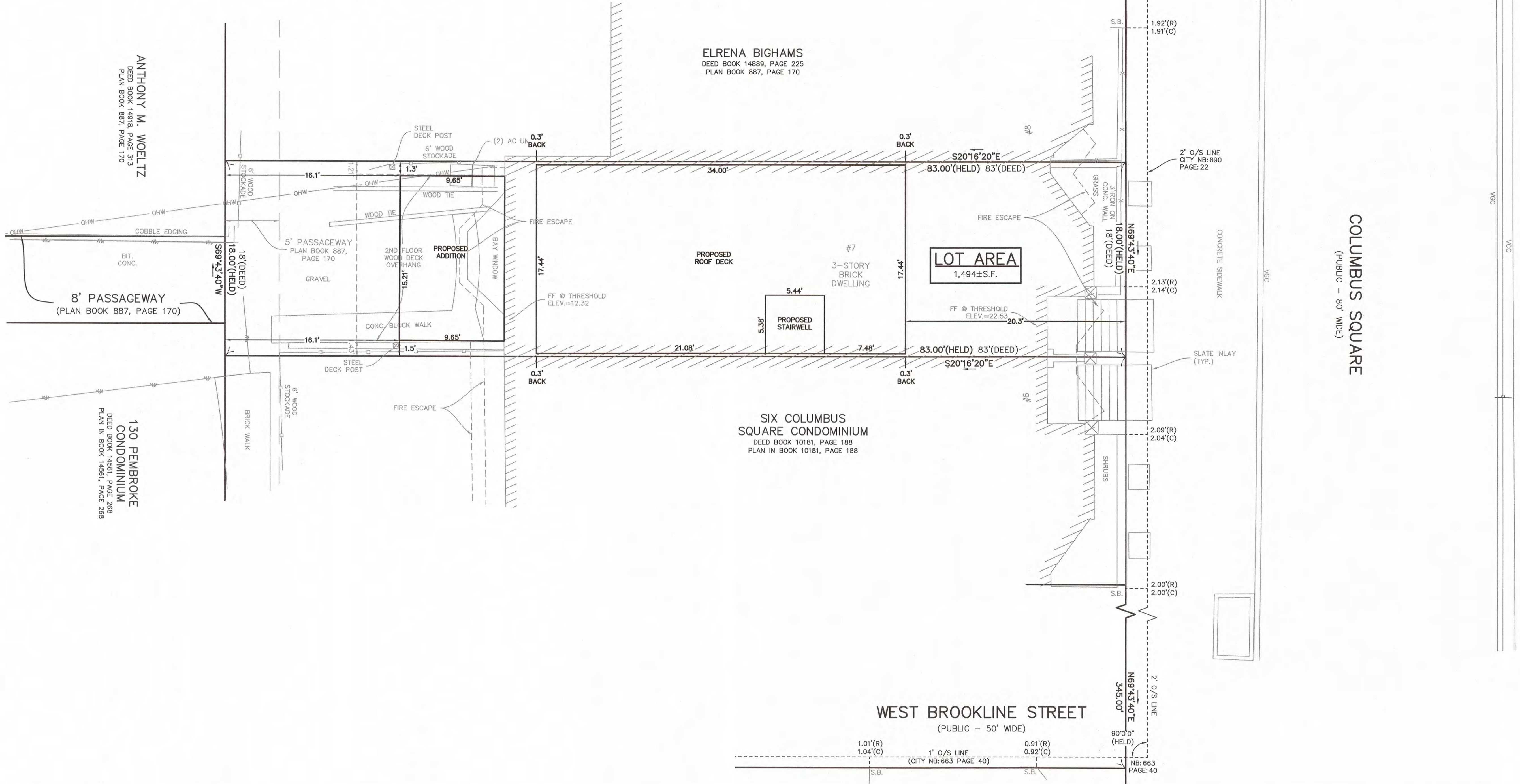
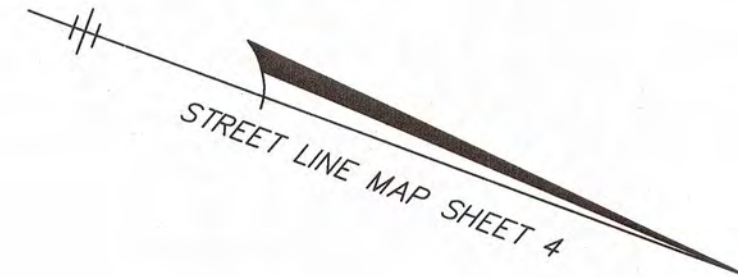

ASSESSORS:

PARCEL ID: 0402838000

REFERENCES:

DEED BOOK 55579, PAGE 161
 PLAN BOOK 887, PAGE 170
 CITY NOTEBOOK: 607, PAGES 126-127
 663, PAGE 40
 890, PAGES 21-22
 CITY LAYOUT L-354
 STREET LINE MAP SHEET S-4
 BY YUNITS ENGINEERING
 B.R.A. SOUTH END PROJECT R-56

RECORD OWNER:

APEIRON PROPERTIES, LLC
 197 WEST SPRINGFIELD STREET
 BOSTON, MA. 02118

ZONING:

SOUTH END NEIGHBORHOOD
 MFR - MULTIFAMILY RESIDENTIAL

NOTES:

1) THIS PLAN WAS CREATED TO SHOW THE PROPOSED BUILDING ADDITION SITUATED ONTO THE EXISTING LOT

#7 COLUMBUS SQUARE

Danvers, Massachusetts 01923

PREPARED FOR:

APEIRON PROPERTIES, LLC

197 West Springfield Street
 Boston, Massachusetts 02118

HANCOCK ASSOCIATES

Civil Engineers
 Land Surveyors
 Wetland Scientists

121 EAST BERKELEY STREET, BOSTON, MA 02118
 VOICE (617) 357-8145, FAX (617) 357-9495
 WWW.HANCOCKASSOCIATES.COM

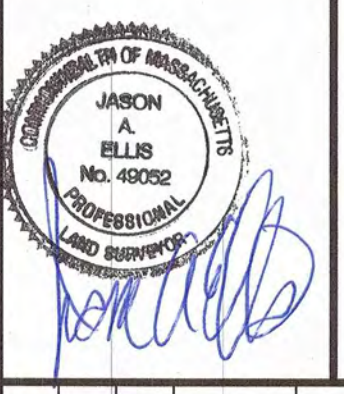

NO.	BY	APP	DATE	ISSUE/REVISION	DESCRIPTION

DATE: 5/12/20 DRAWN BY: JML
 SCALE: 1"=5' CHECK BY: JAE

PROPOSED PLOT PLAN OF LAND IN BOSTON, MA

PLOT DATE: May 26, 2020 7:59 am
 PATH: O:\Civil 3D Projects\23451 - Apeiron - South End\DWG\

DWG: 23451pp.dwg
 LAYOUT: Plot Plan
 SHEET: 1 OF 1
 PROJECT NO.: 23451

COLUMBUS SQUARE
 (PUBLIC - 80' WIDE)

WEST BROOKLINE STREET
 (PUBLIC - 50' WIDE)

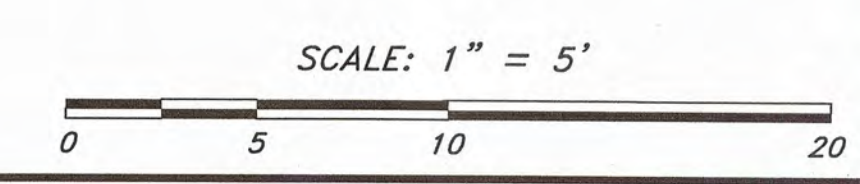

OWNER
Apeiron Properties LLC
C/O Jeffrey Wager
197 West Springfield Street
Boston, MA 02118

ARCHITECT
Aaron J. Weinert Design Studio LLC
d/b/a Studio DRAW
330 Washington Street #2
Boston, Massachusetts 02108
617.588.0071
www.studio-draw.com

CONTRACTOR

SURVEYING & SITE ENGINEERING
Hancock Associates
185 Center Street
Danvers, MA 01720
978.777.3950

STRUCTURAL ENGINEERING
Siegel Associates
860 Walnut Street
Newton, MA 02459
617.244.1612

FIRE PROTECTION ENGINEERING
Adams Fire Protection
75 First Street #8
Bridgewater, MA 02324
508.279.0014

Columbus Square Residence
7 Columbus Sq. Boston MA

exterior elevations

SCHEMATIC DESIGN

Draw #1700X
Date: 04/08/20

Scale: 1/4" = 1'-0"

Drawn: PS

A4.00



1 Existing South Elevation Copy 1/4" = 1'-0"

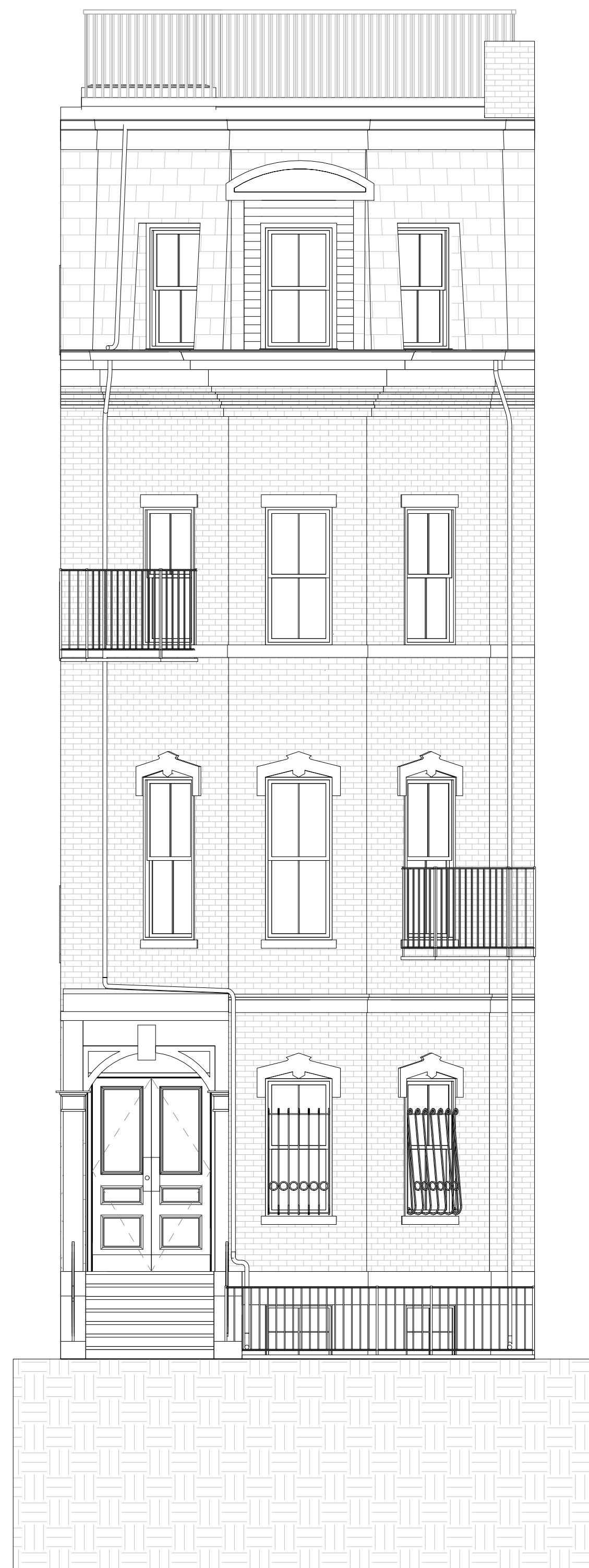

2 Proposed Front Elevation 1/4" = 1'-0"



3 Existing North Elevation Copy 1/4" = 1'-0"

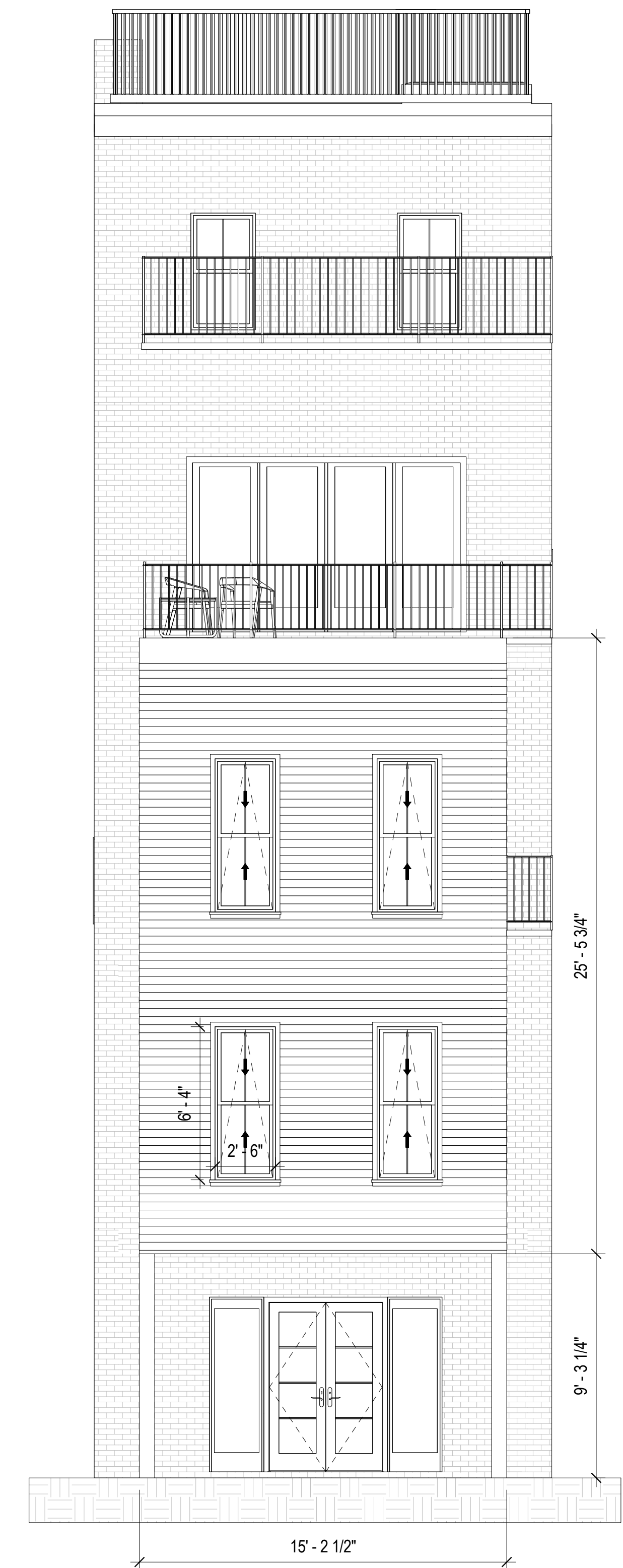

4 Proposed Rear Elevation 1/4" = 1'-0"



FROM W NEWTON & COLUMBUS AVE Photo taken 4/21/2020



FROM COLUMBUS AVE

Photo taken 4/21/2020



FROM COLUMBUS AVE

Photo taken 4/21/2020



FROM BRADDOCK PARK

Photo taken 4/21/2020



FROM W NEWTON & COLUMBUS AVE Photo taken 4/21/2020

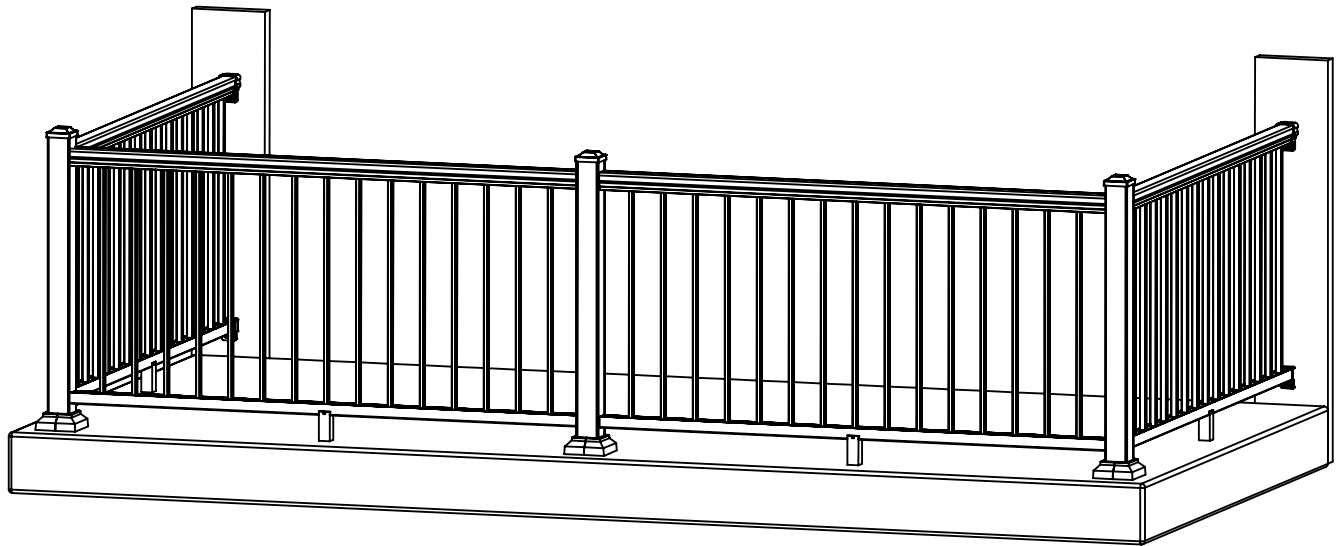

ISOMETRIC VIEW

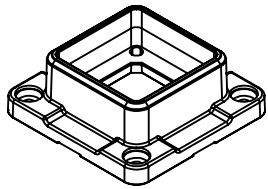

POST BASE
(PART NUMBER VARIES BY SIZE)

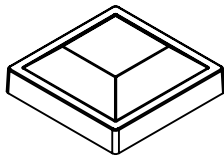

POST CAP
(PART NUMBER VARIES BY SIZE)

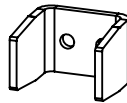

RAIL PANEL CLIP
CL09410

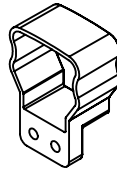

TOP RAIL WALL MOUNT
(PART NUMBER VARIES BY STYLE)



BOTTOM RAIL WALL MOUNT
(PART NUMBER VARIES BY STYLE)

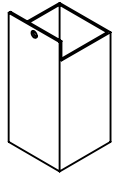

RAIL PANEL SUPPORT LEG
(PART NUMBER VARIES BY STYLE)

PART REFERENCE

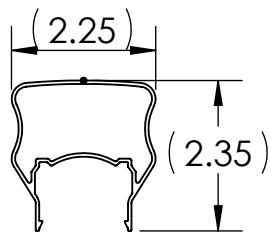

COLONIAL SERIES
CT293100

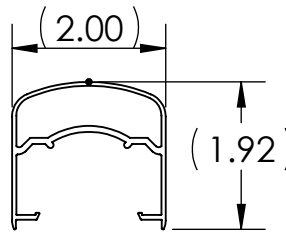

MISSION SERIES
MT193100

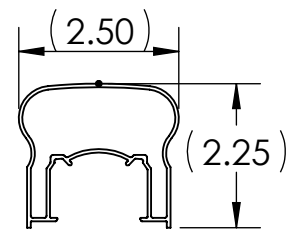

VICTORIAN SERIES
VT393100

TOP RAIL PROFILE OPTIONS

PROPRIETARY AND CONFIDENTIAL

THE INFORMATION CONTAINED IN THIS DRAWING IS THE SOLE PROPERTY OF UltraLox.
ANY REPRODUCTION IN PART OR AS A WHOLE WITHOUT THE WRITTEN PERMISSION OF UltraLox IS NOT PERMITTED.

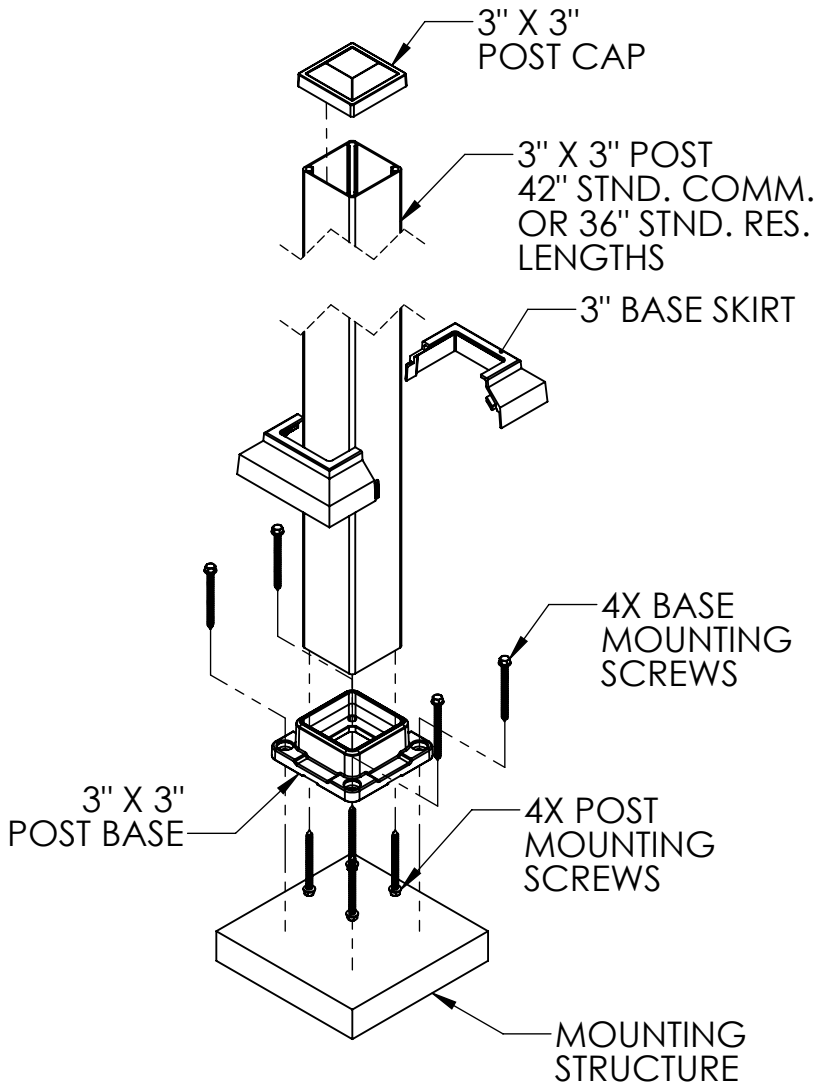

POST DETAIL

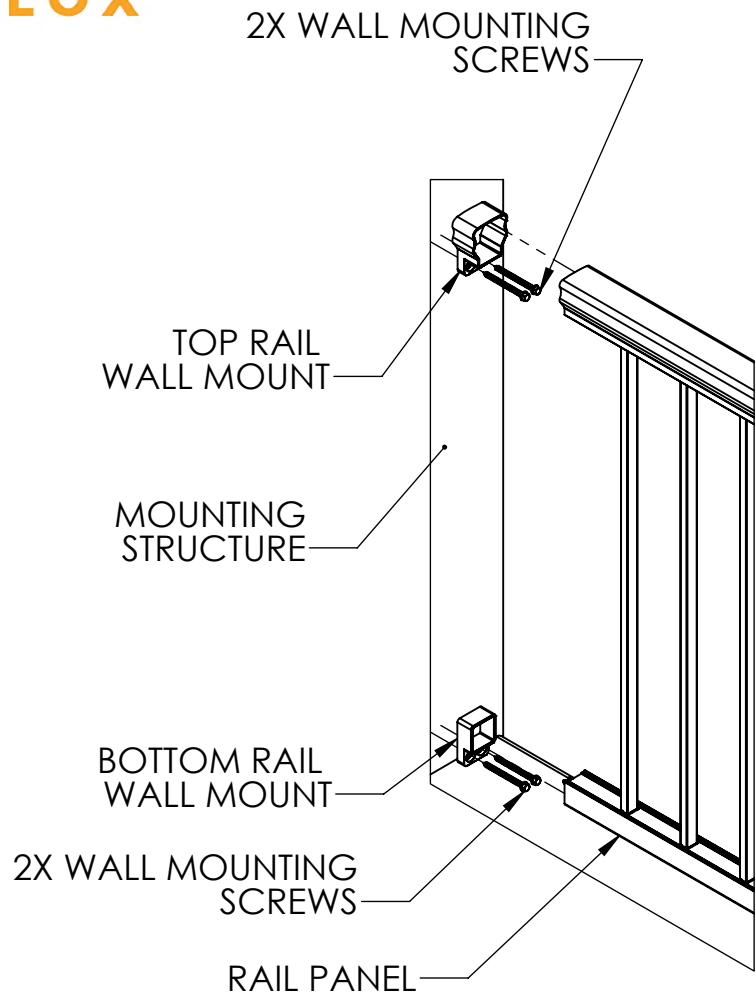

WALL MOUNT DETAIL

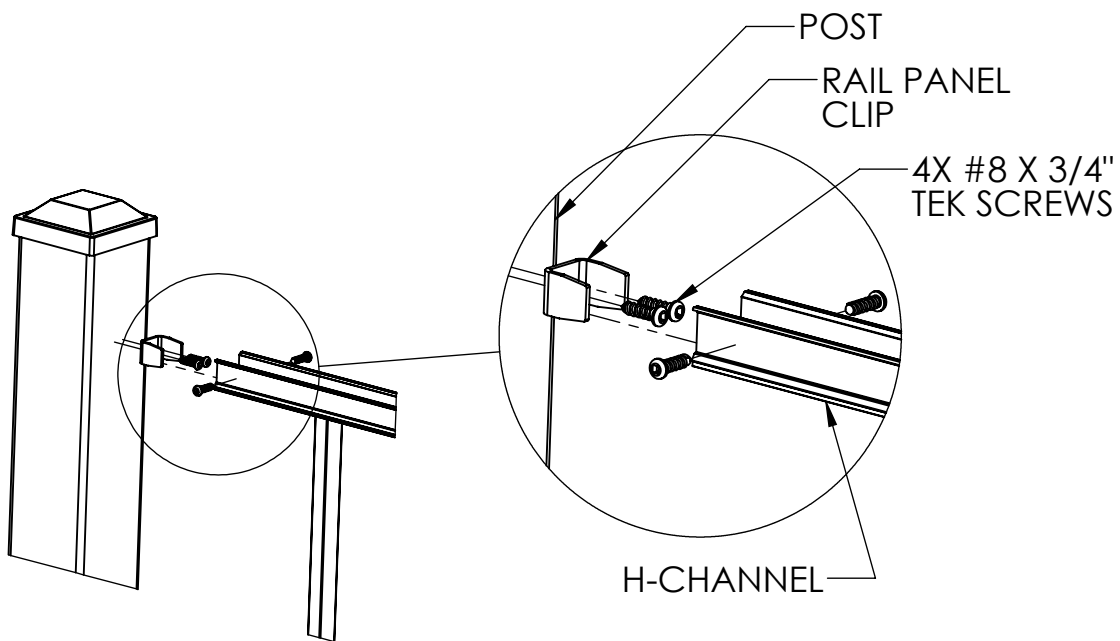

RAIL PANEL CLIP DETAIL