

23 UPTON STREET ROOFTOP HEADHOUSE DOCUMENTATION

08-10-20

PREPARED FOR SOUTH END LANDMARK DISTRICT COMMISSION

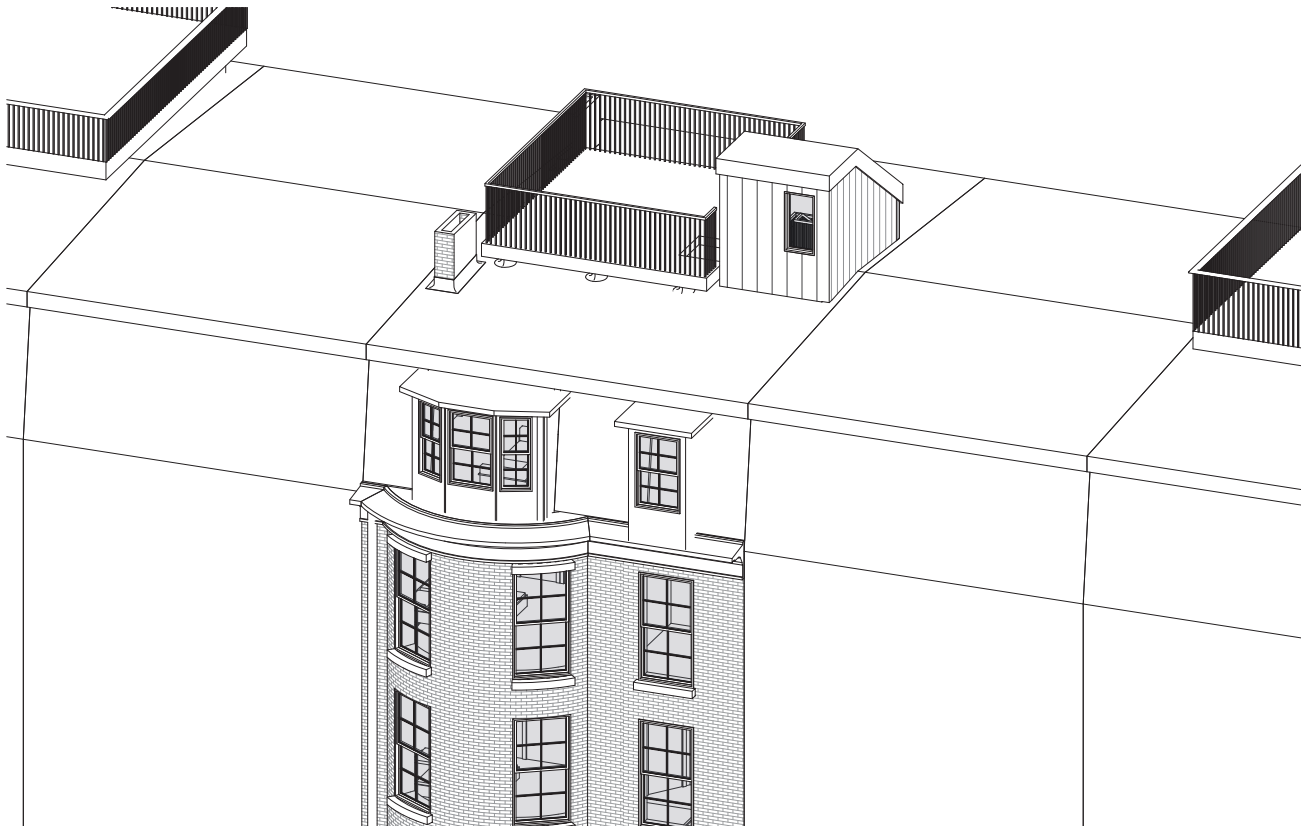

FLOOR PLANS - EXISTING ROOF PLAN WITH PHOTOS

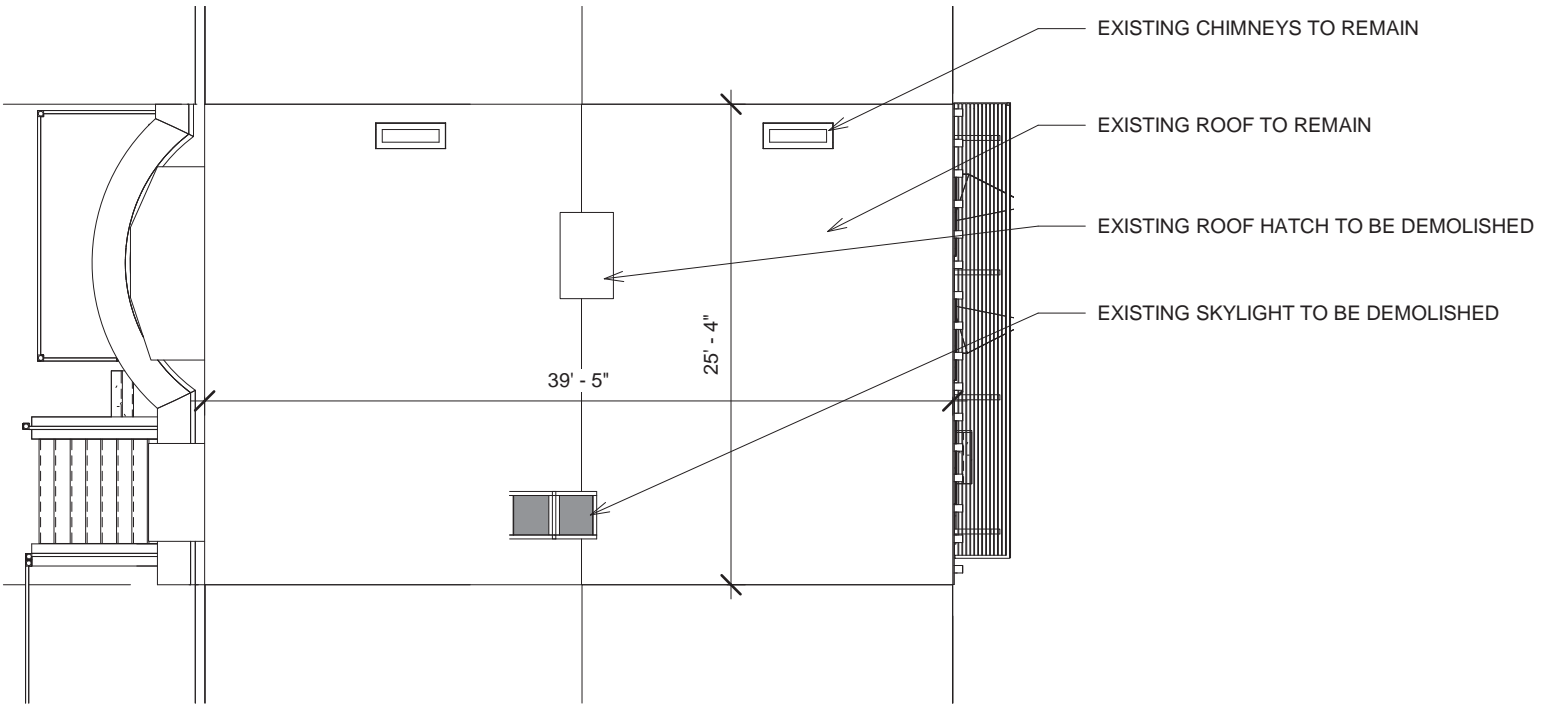

FLOOR PLANS - PROPOSED ROOF PLAN WITH MOCKUP PHOTOS

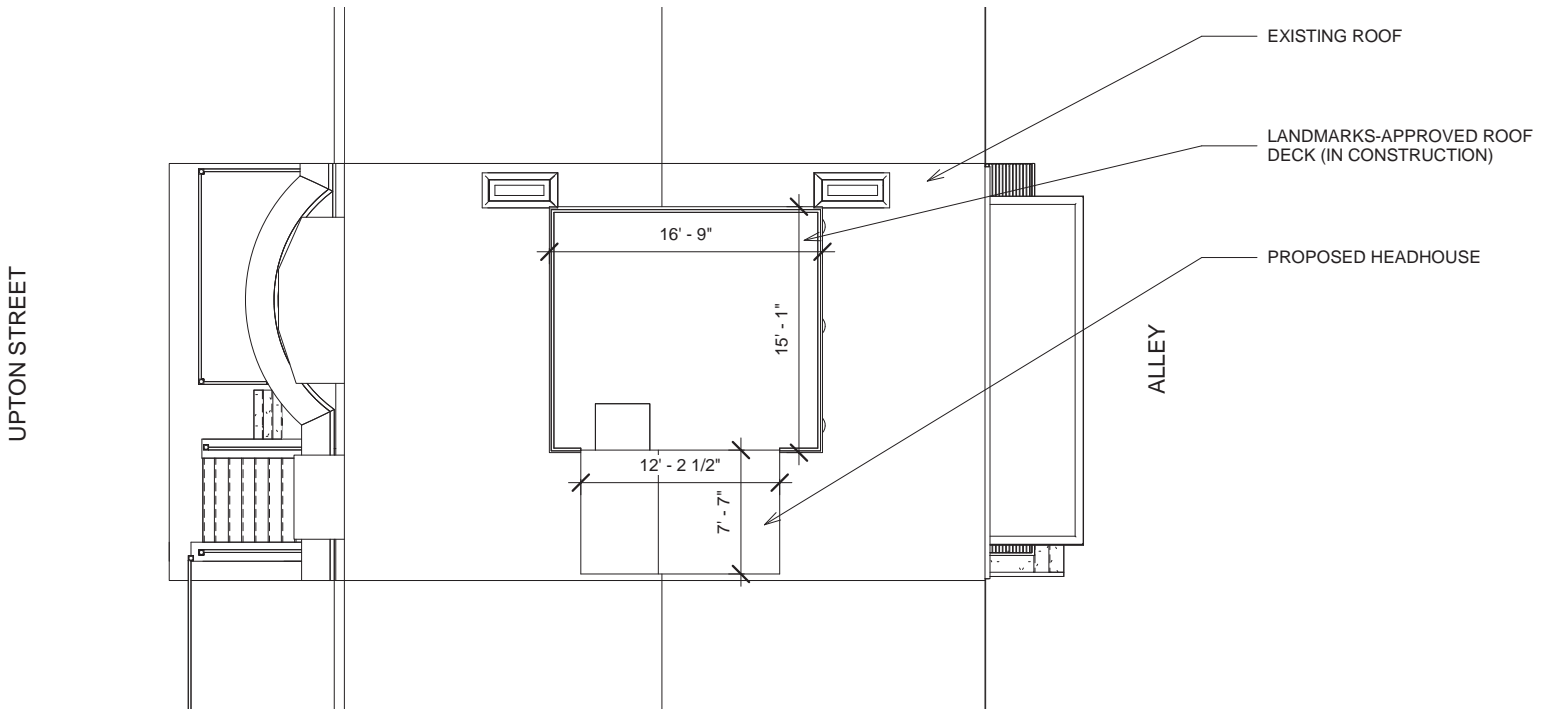

PROPOSED MOCKUP DRAWINGS

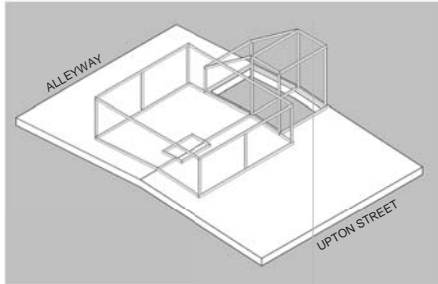

① Headhouse Mockup

UPTON

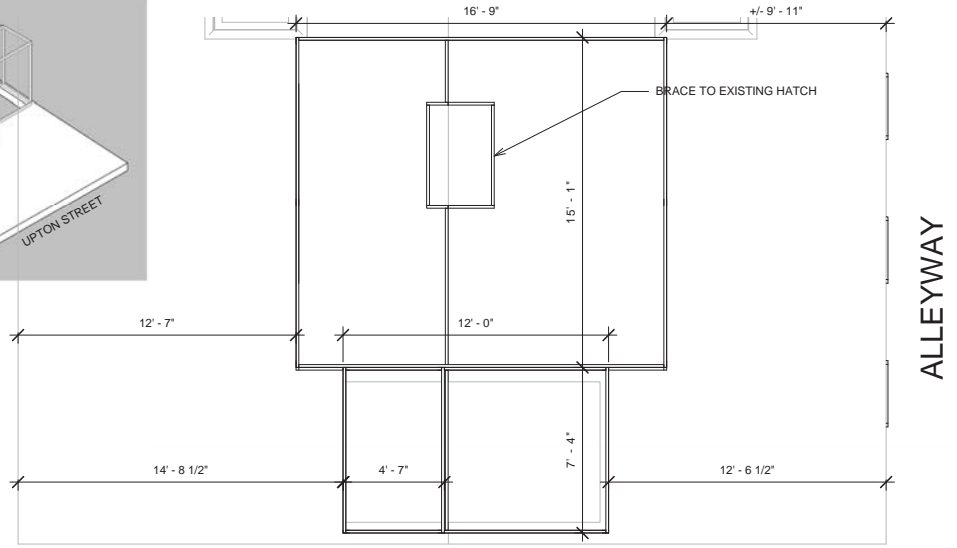

ALLEYWAY

② Proposed Mockup Plan
1/4" = 1'-0"

UPTON STREET

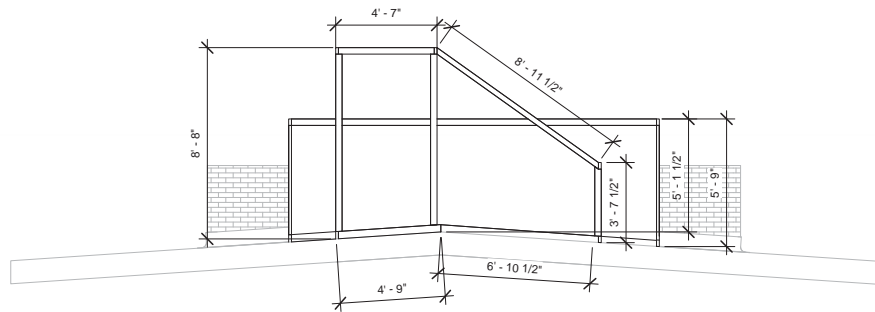

ALLEYWAY

③ Proposed Mockup South Elevation
1/4" = 1'-0"

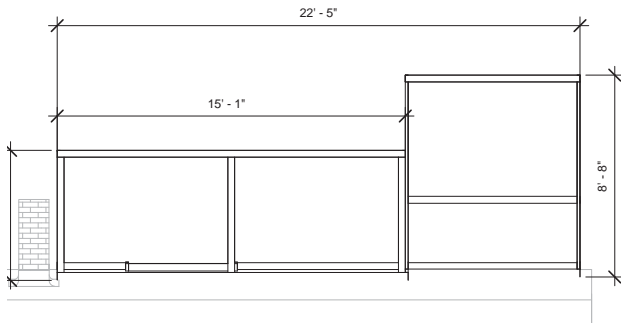

① Proposed Mockup Front Elevation
1/4" = 1'-0"

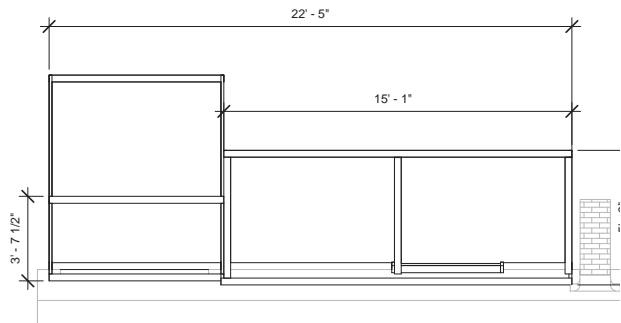

② Proposed Mockup Back Elevation
1/4" = 1'-0"

PROPOSED FRONT AND BACK ELEVATIONS



PROPOSED SIDE ELEVATION

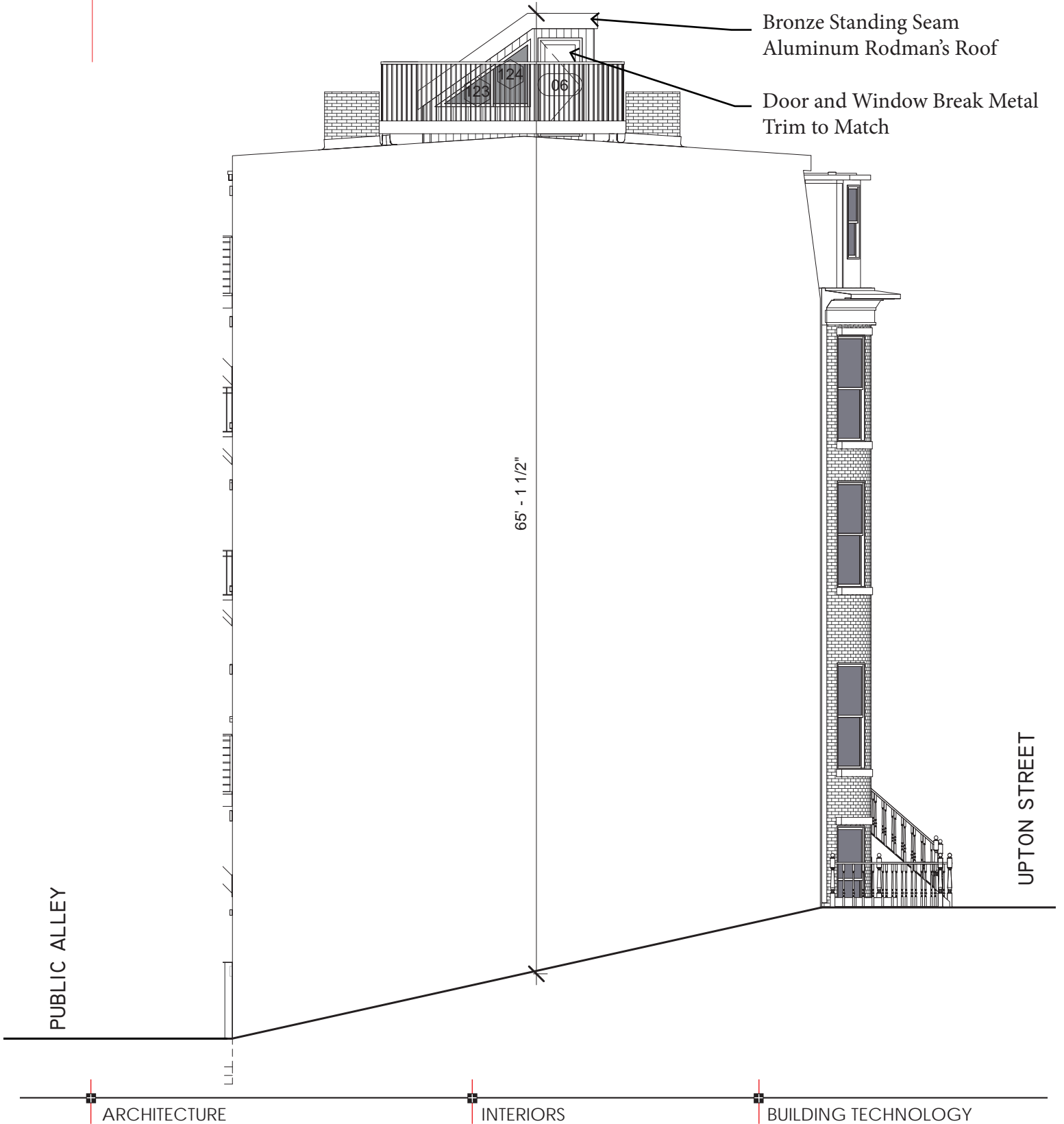

PROPOSED VISIBILITY FROM STREET

