



22 BRADDOCK PARK - STREET VIEW



WINDOW LOCATION LEGEND



WINDOW 'A' - FOURTH FLOOR (MISSING)



WINDOW 'B' - FOURTH FLOOR

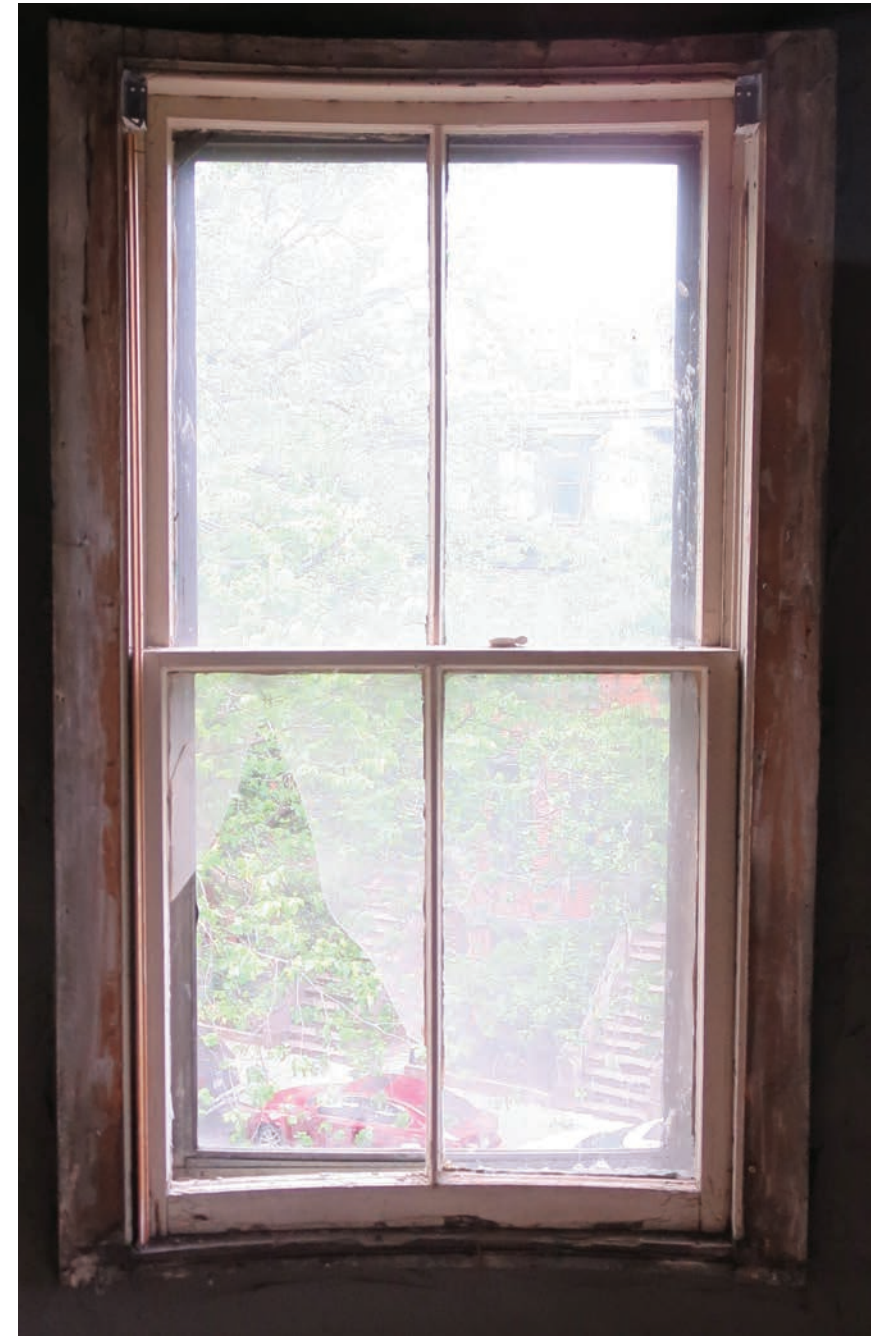

WINDOW 'C' - FOURTH FLOOR



WINDOW 'D' - FOURTH FLOOR (MISSING)



WINDOW 'E' - THIRD FLOOR



WINDOW 'F' - THIRD FLOOR



WINDOW 'G' - SECOND FLOOR



WINDOW 'H' - SECOND FLOOR



WINDOW 'I' - FIRST FLOOR



WINDOW 'J' - FIRST FLOOR



WINDOW 'C' - FRAME AND SASH DAMAGE
BROKEN GLASS PANE



WINDOW 'C' - FRAME AND SASH DAMAGE



WINDOW 'B' - FRAME AND SASH DAMAGE
MISSING WINDOW STOP



WINDOW 'E' - FRAME DAMAGE



WINDOW 'E' - FRAME AND SASH DAMAGE



WINDOW 'F' - SILL AND FRAME DAMAGE



WINDOW 'F' - SILL AND FRAME DAMAGE



WINDOW 'F' - MISSING WINDOW STOP



WINDOW 'H' - SASH DAMAGE
COUNTER-WEIGHT NEEDS REPLACED



WINDOW 'G' - SASH DAMAGE
BROKEN GLASS PANE



WINDOW 'G' - COUNTER-WEIGHT



WINDOW 'G' - SILL AND FRAME DAMAGE



CRACKED RAIL



SPLINTERING AT DOOR CORNERS

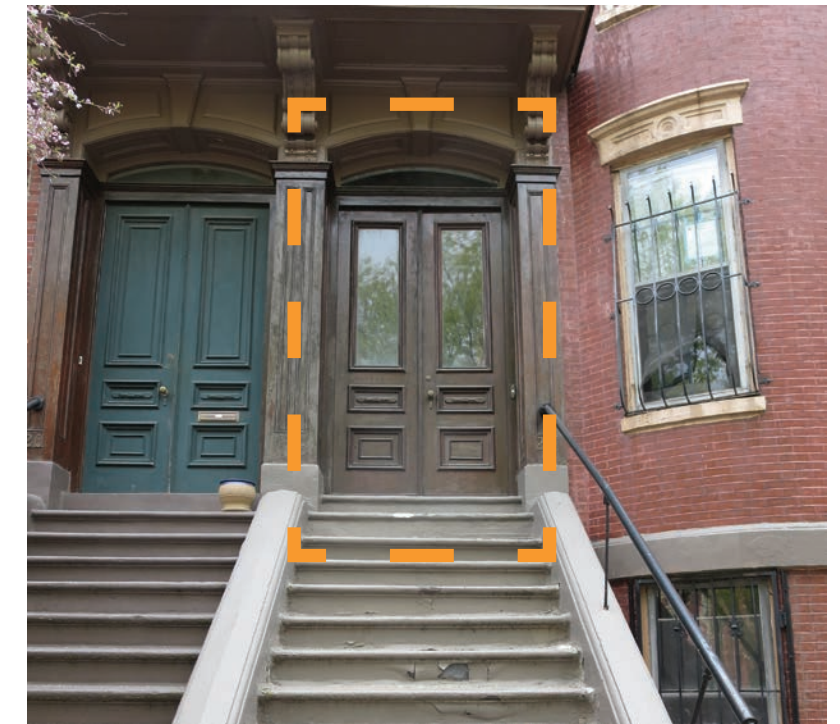

FRONT ENTRY DOOR - SECOND FLOOR



CRACKING AT RAIL



MOULDING IS SEPERATING FROM THE DOOR



PUTTY GLAZING CRACKING



SIDE ENTRY DOOR - FIRST FLOOR



STAIRCASE



FENCING



WINDOW GRILLES

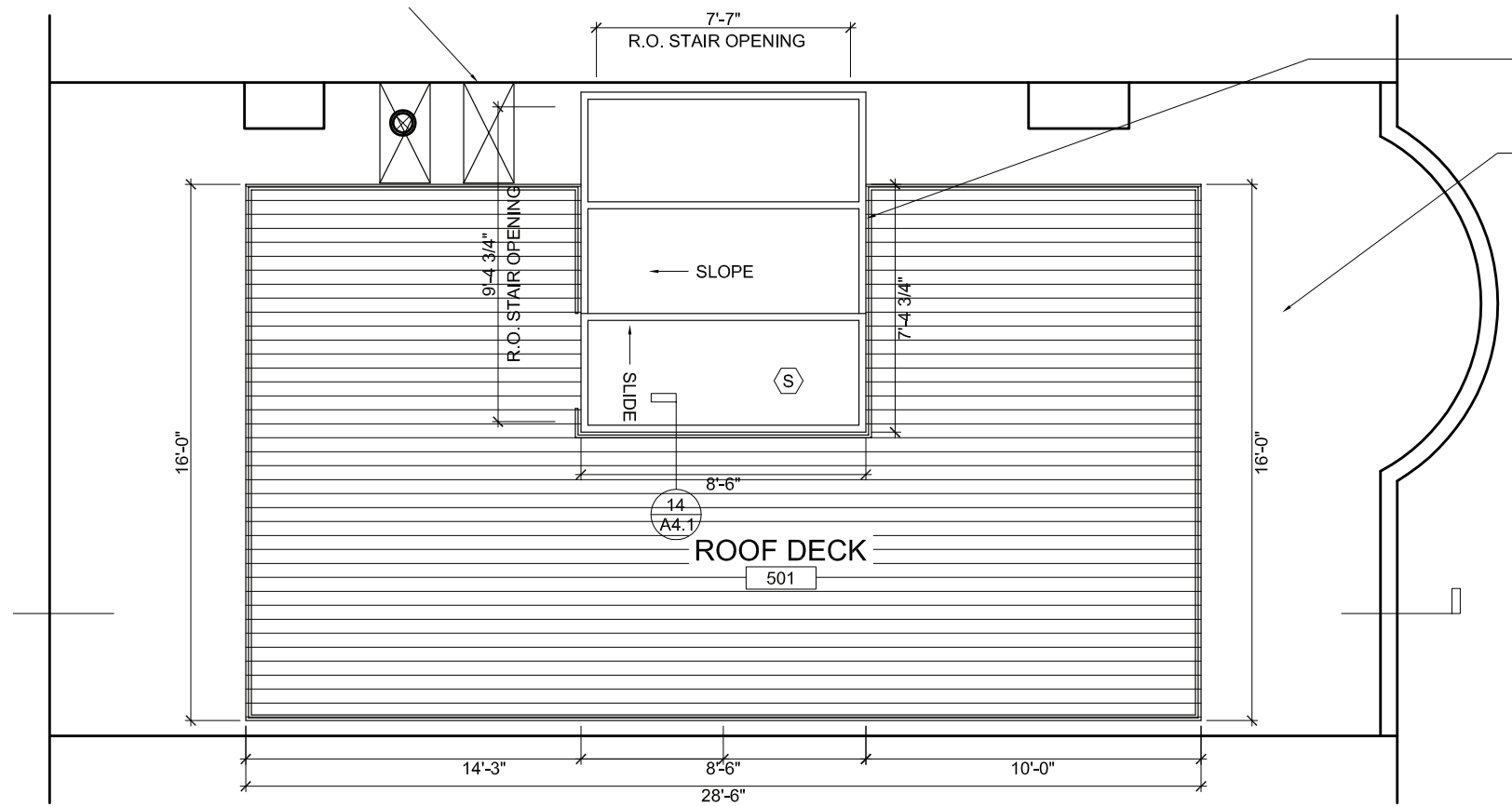

ROOF PLAN -
SETBACK TO MINIMIZE VIEW FROM STREET



VIEW FROM BRADDOCK PARK



SIMILAR TO STEEL RAILING - PAINTED BLACK

SEEN AS EXTERIOR VIEW

H. HIRSCHMANN LTD		
482 Shelton Avenue, West Rutland, VT 05777		
DATE: 02/27/20	SCALE: 1"=1'	Approved by:
JOB NO.:	DRAWN BY:	
BENT WINDOWS		
		A1

UNIT SPECIFICATIONS	
WOOD SPECIES:	SOUTH AMERICAN MAHOGANY
GLASS AND GLAZING:	ARGON FILLED FLAT ANNEALED 9/16" PILKINGTON ENERGY ADVANTAGE (PEA) LOW-E, WARM EDGE IGU (1/8" PEA, 5/16" ARGON, 1/8" CLEAR)
HARDWARE:	PHELPS SP225BBRE BRASS BALL BEARING PULLEYS W/ ARC CHAIN #35
DOUBLE HUNG WINDOWS:	PHELPS LKF18 SASH LOCKS PHELPS LF23 SASH LIFTS ALUMINUM SCREEN CLEAT PAINTED TO MATCH EXTERIOR
HARDWARE FINISH:	TBD
SCREEN:	FABRICO FRAME #861 PAINTED TO MATCH EXTERIOR, ULTRA VIEW SCREEN MESH
INTERIOR FINISH:	(2x PRIME COAT, 2x TOP COAT) OIL BASED FPE COLOR TBD
EXTERIOR FINISH:	(2x PRIME COAT, 2x TOP COAT) OIL BASED FPE COLOR TBD

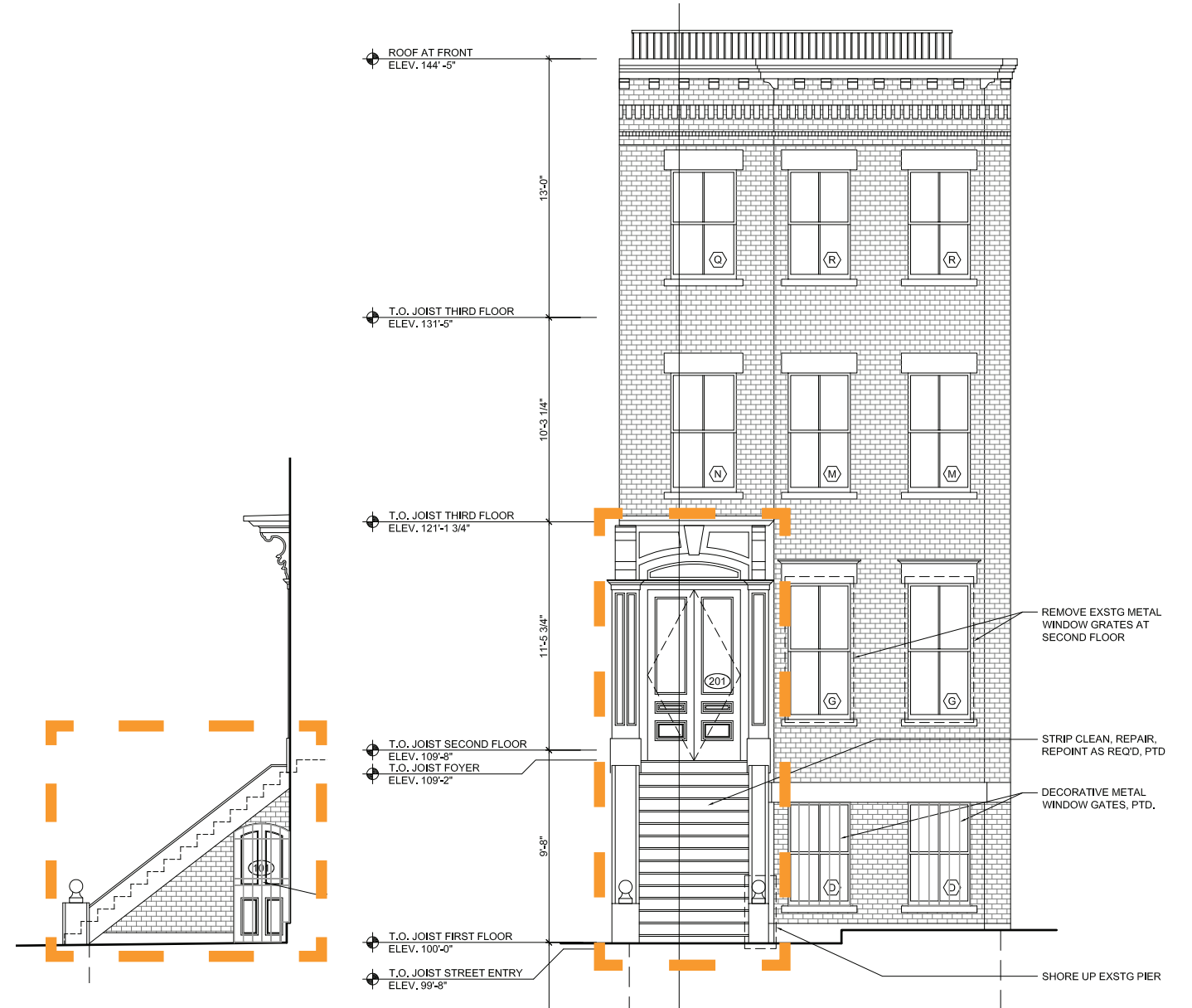
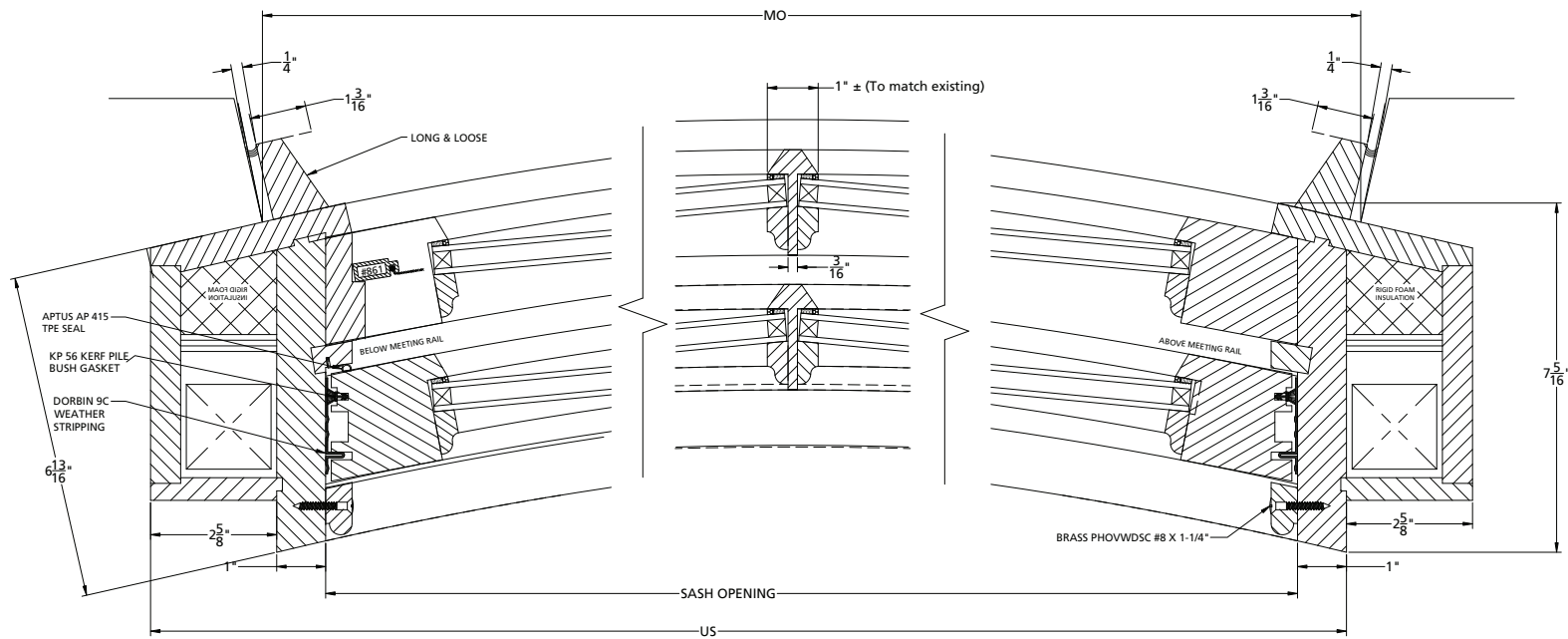
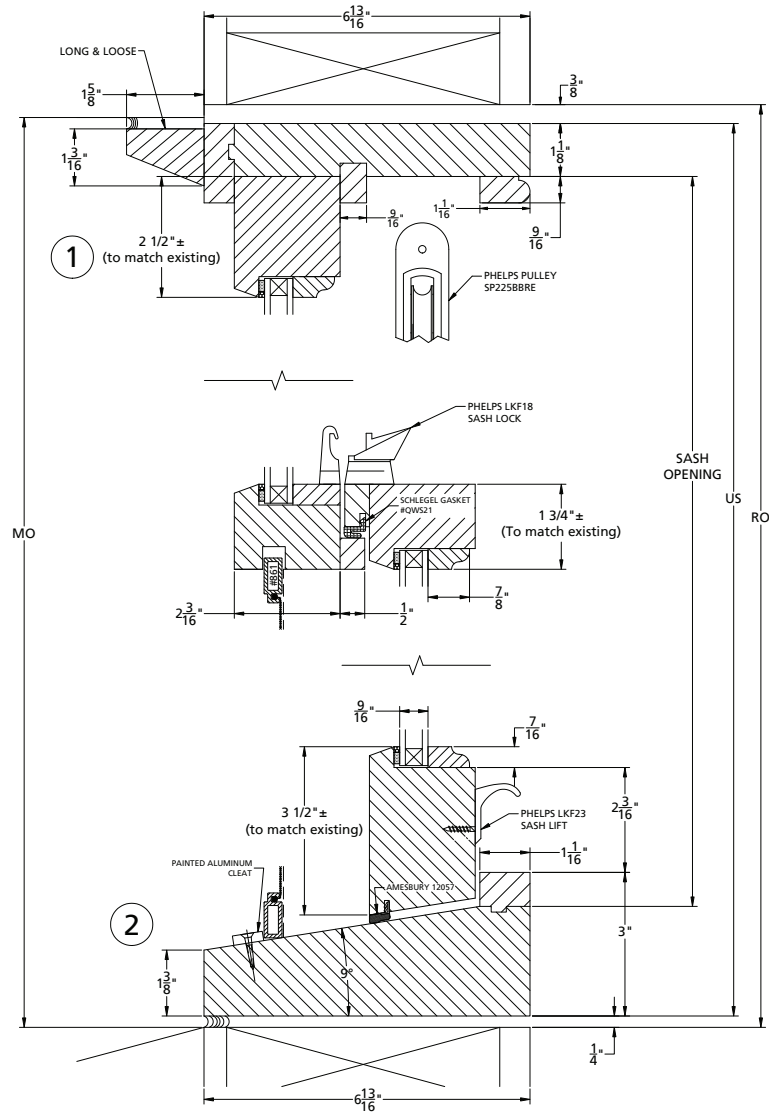
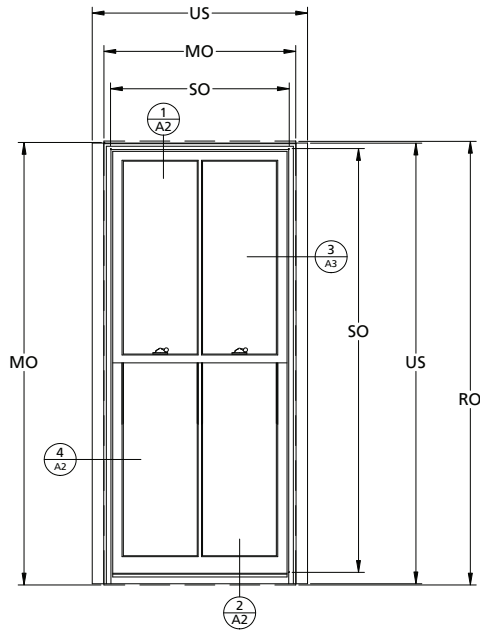

PATCH AND REPAIR FRONT STAIRCASE
 PATCH AND REPAIR BRICK UNDER FRONT STAIRCASE
 PATCH AND REPAIR EXISTING FRONT ENTRY DOOR
 NEW SIDE ENTRY DOOR TO MATCH EXISTING

WINDOW ELEVATION AND DETAILS



SIMILAR TO 35 BRADDOCK PARK WINDOW GRILLE



SIMILAR TO 19 BRADDOCK PARK FENCE

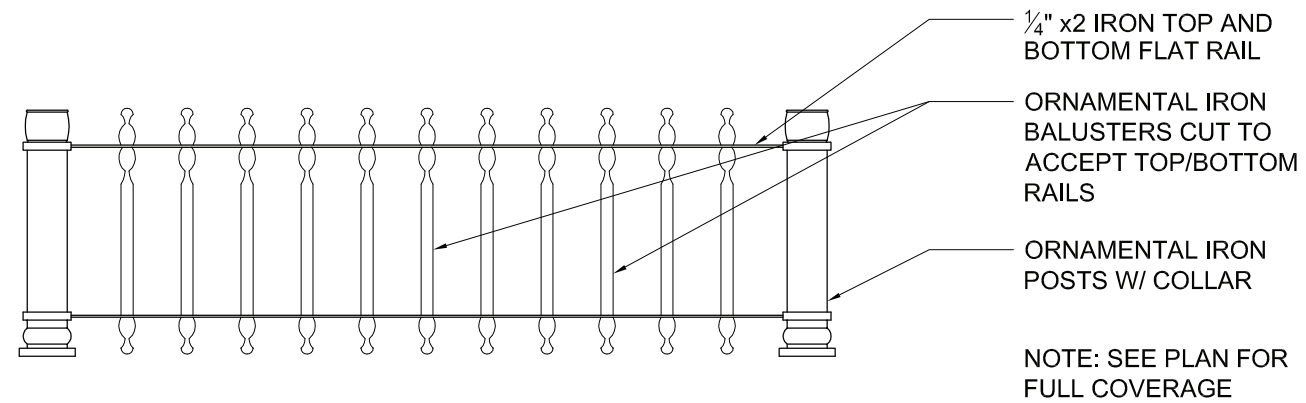

5 GARDEN FENCE
 1/2"=1'-0"

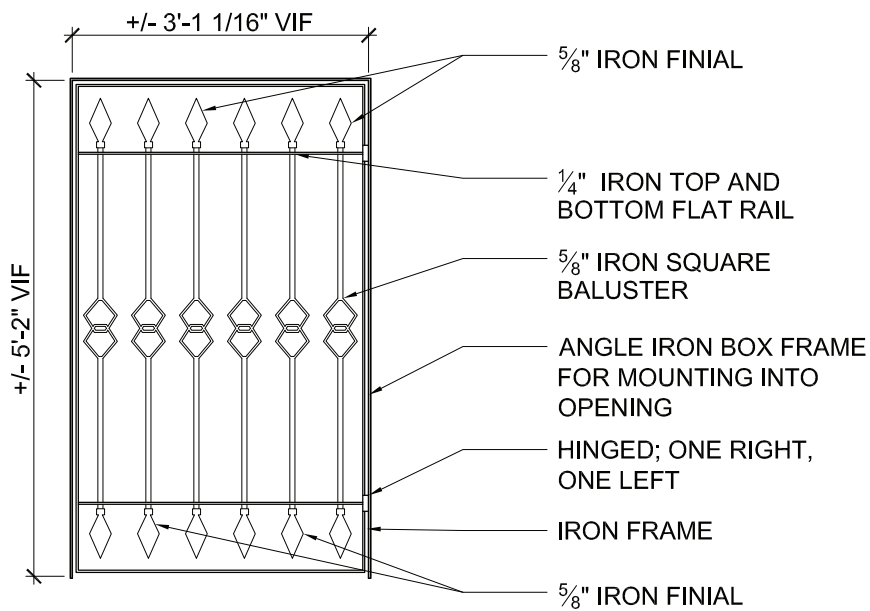

5 WINDOW SECURITY GRILLE
 1/2"=1'-0"

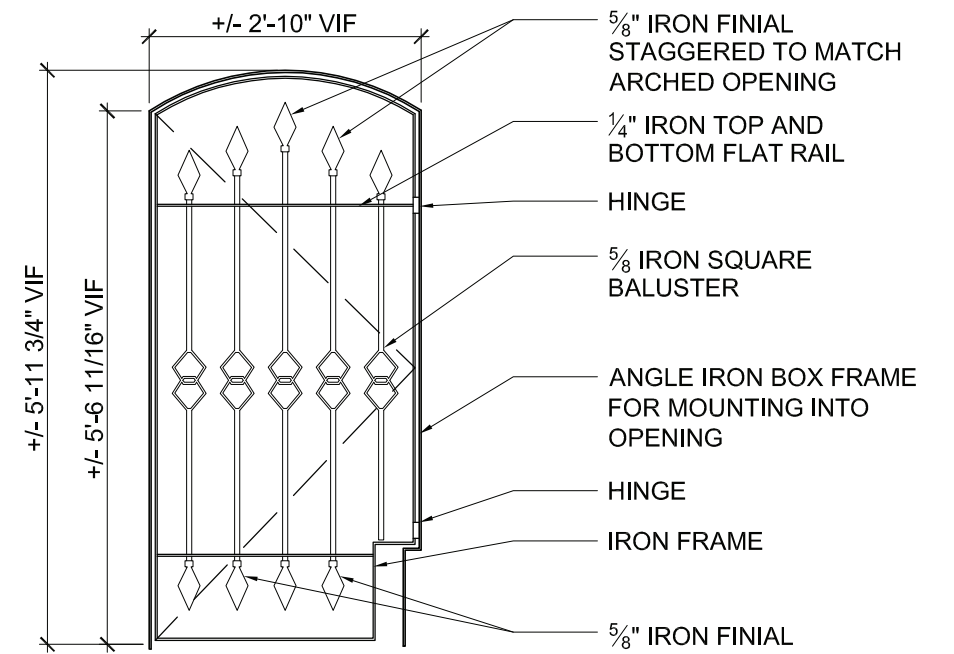

5 DOOR SECURITY GRILLE
 1/2"=1'-0"

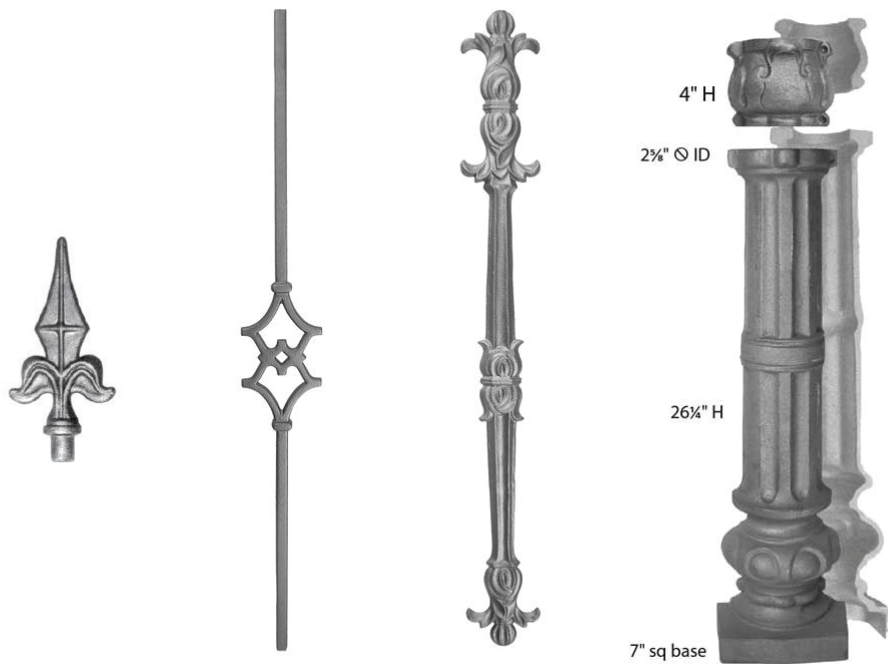

FENCE & GRILLE COMPONENTS - PAINTED BLACK