

Santander #0612 346 Congress St Boston, MA 02210 **OPTION 1**

****Preliminary rendering for concept only;
tech survey and code check to follow**

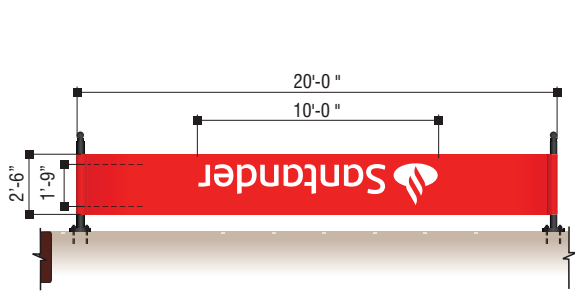

EXISTING CONDITION



**1 NEW D/F FLAG SIGN 50 sq. ft.
SCALE: 3/16" = 1'-0"
Qty 1**



PROPOSED RENDERING

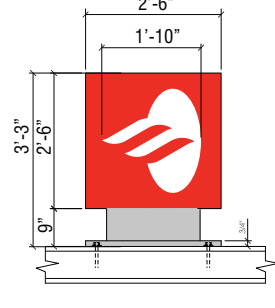

**2 NEW D/F BLADE SIGN 6.25 sq. ft.
SCALE: 3/16" = 1'-0"
Qty 1**



ImageOne
INDUSTRIES

677 Dunksferry Rd, Bensalem, PA
978 S. Camino Oro Goodyear, AZ
i1ind.com // 215-826-0880

Exterior Signage

Design and construction documents as instruments of service are given in confidence and remain property of Imagine Industries. The use of design and construction documents for purposes other than the specific project named herein is strictly prohibited without expressed written consent of Imagine Industries.

Client:  **Santander**

Santander #0612
346 Congress St
Boston, MA 02210

Designer
KS

Date
07/01/2019
Revision 7

EXISTING MULTI-STORY BUILDING

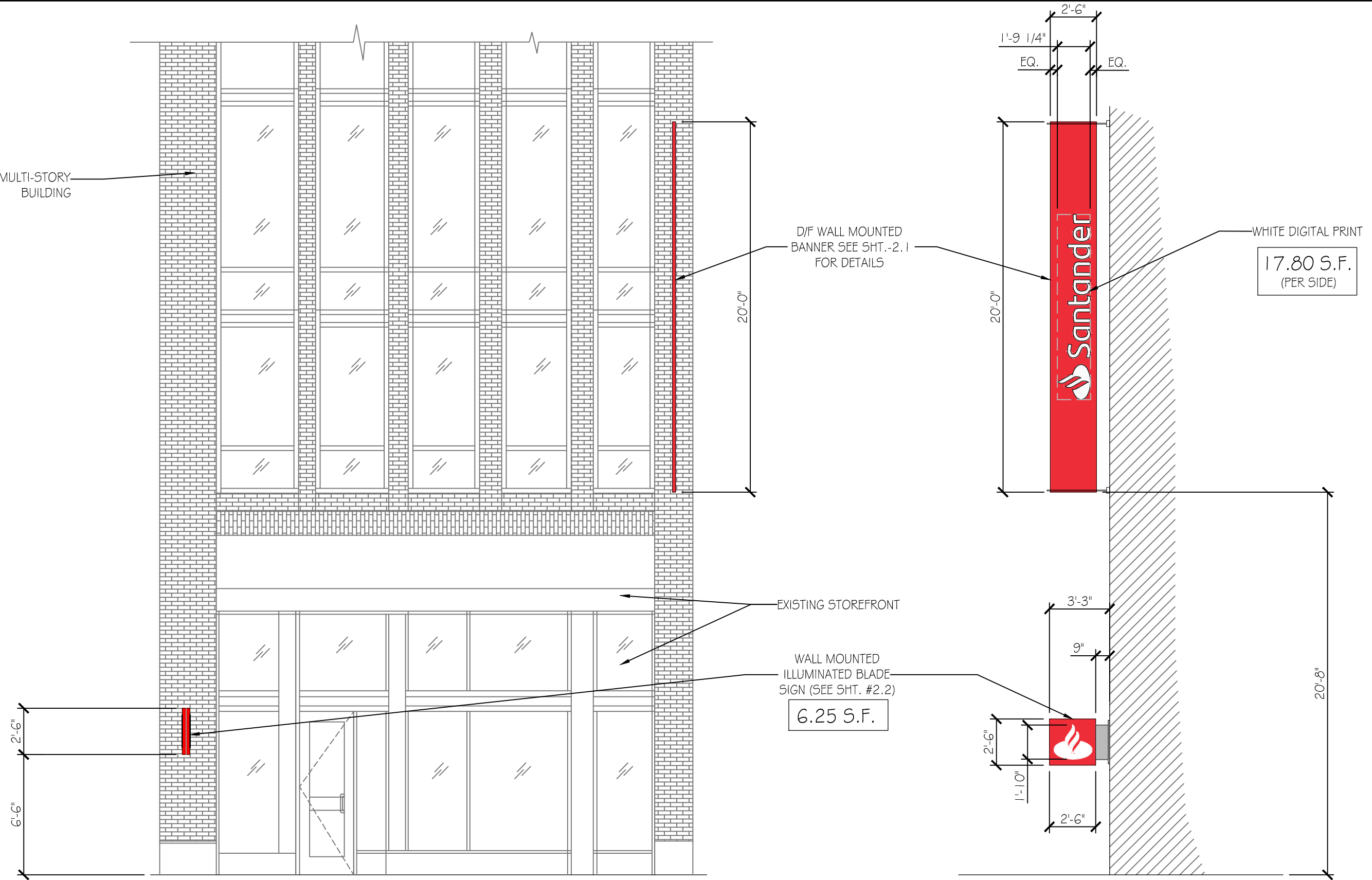

D/F WALL MOUNTED BANNER SEE SHT.-2.1 FOR DETAILS

WHITE DIGITAL PRINT

17.80 S.F.
(PER SIDE)

EXISTING STOREFRONT

WALL MOUNTED ILLUMINATED BLADE SIGN (SEE SHT. #2.2)

6.25 S.F.

ARTWORK SHOWN ON THIS DRAWING IS SHOWN FOR REPRESENTATION ONLY. ACTUAL ARTWORK TO BE PROVIDED PRIOR TO FABRICATION

ELEVATION OF STORE FRONT

SCALE: 3/16" = 1'-0"

SIDE VIEW (TYPICAL)

SCALE: 3/16" = 1'-0"



677 Dunksferry Road Bensalem, PA 19020 | 978 S. Camino Oro Drive Goodyear, AZ 85338

(215) 826-0880 (215) 826-0514 www.i1ind.com

DESIGN AND CONSTRUCTION DOCUMENTS AS INSTRUMENTS OF SERVICE ARE GIVEN IN CONFIDENCE AND REMAIN THE PROPERTY OF IMAGE ONE IND. THE USE OF THIS DESIGN AND CONSTRUCTION DOCUMENTS FOR PURPOSES OTHER THAN THE SPECIFIC PROJECT NAMED HERE IN IS STRICTLY PROHIBITED WITHOUT THE EXPRESS WRITTEN CONSENT OF IMAGE ONE INDUSTRIES.

REVISIONS			
REV	DATE	DESCRIPTION	BY
1	06.21.19	REMOVED BAND SIGN	MPG



DRAWN BY LR DATE 05.20.19
LOCATION STORE# 612 346 CONGRESS ST. BOSTON, MA. 02210

JOB # 12-654 SCALE AS NOTED
DRAWING TITLE STOREFRONT SIGNS ELEVATIONS OVERALL DIMENSIONS

DRAWING NUMBER 12654-2.0

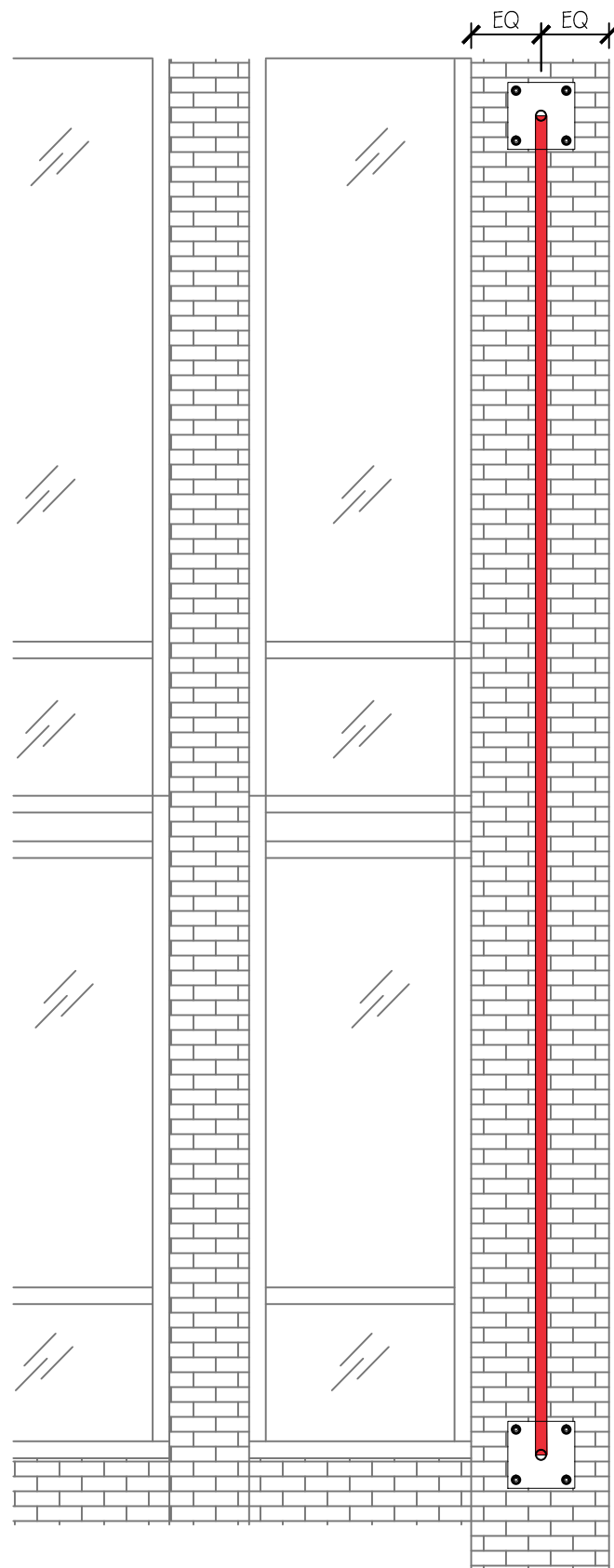

PARTIAL FRONT ELEV.
SCALE: 3/8" = 1'-0"

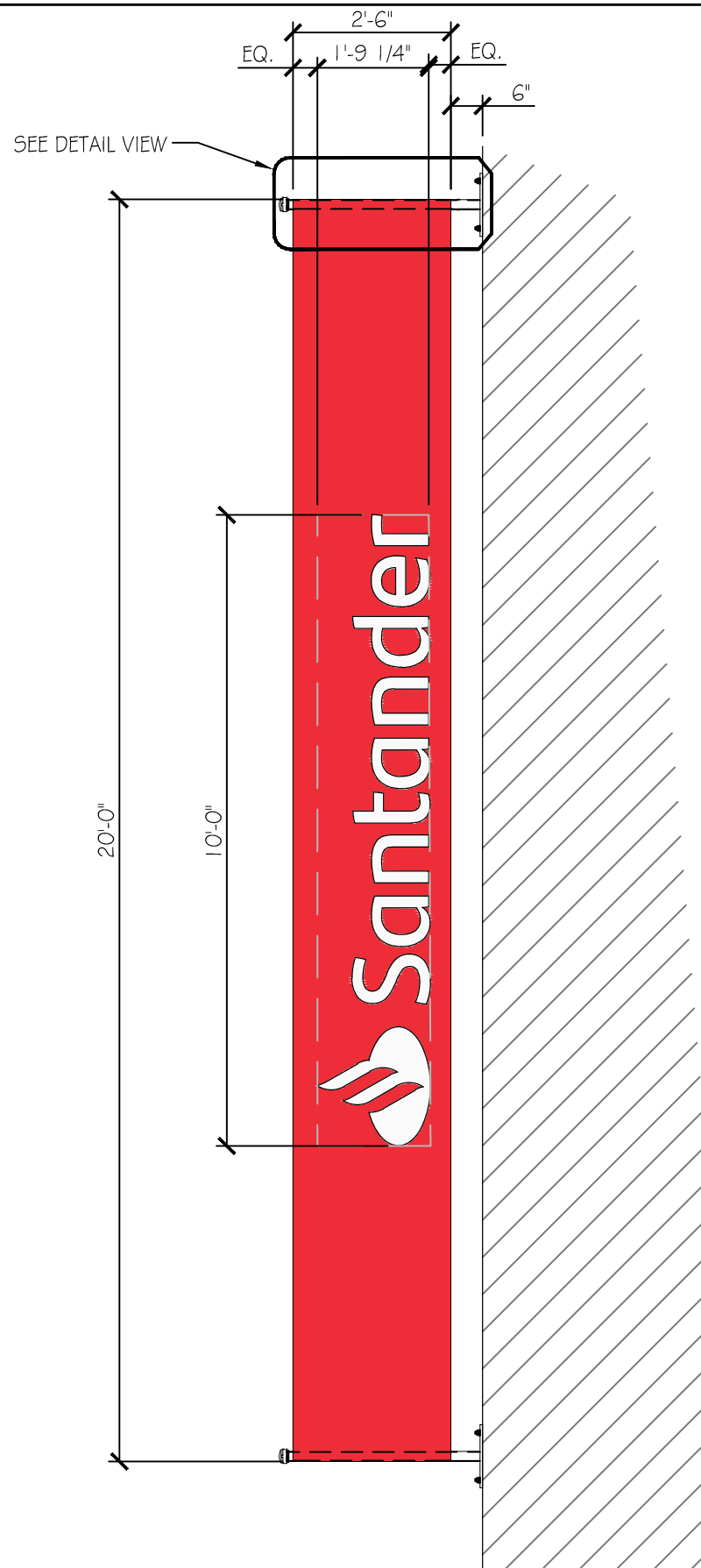

TYP END VIEW
SCALE: 3/8" = 1'-0"

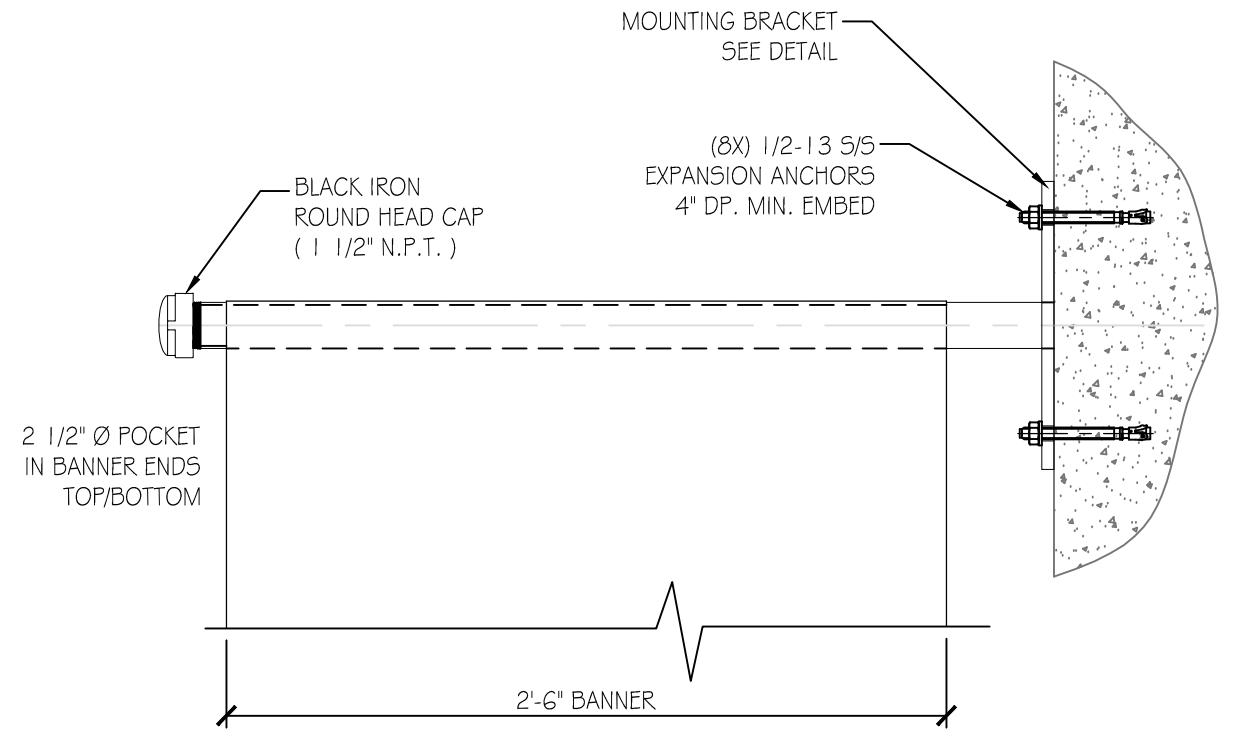

DETAIL VIEW
SCALE: 1 1/2" = 1'-0"

*FIELD VERIFY
CONCRETE COLUMN
CONSTRUCTION

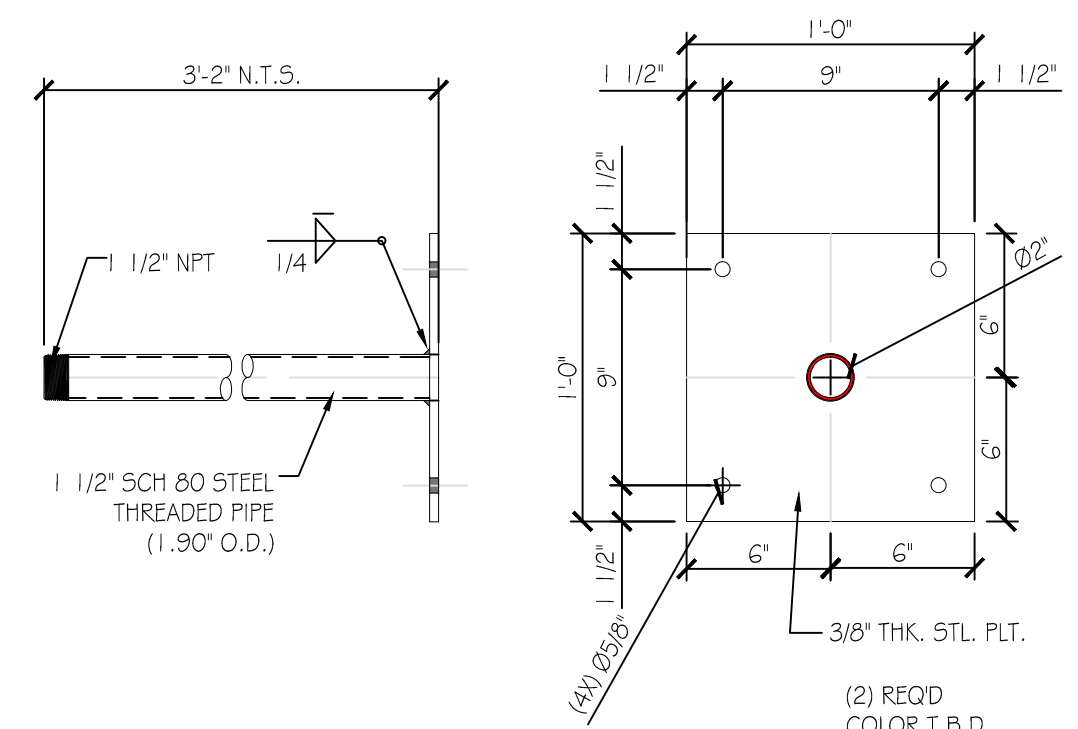

MOUNTING BRACKET DETAIL
SCALE: 1 1/2" = 1'-0"

REVISIONS			
REV	DATE	DESCRIPTION	BY
1	06.21.19	ADDED THIS DETAIL SHEET	MPG

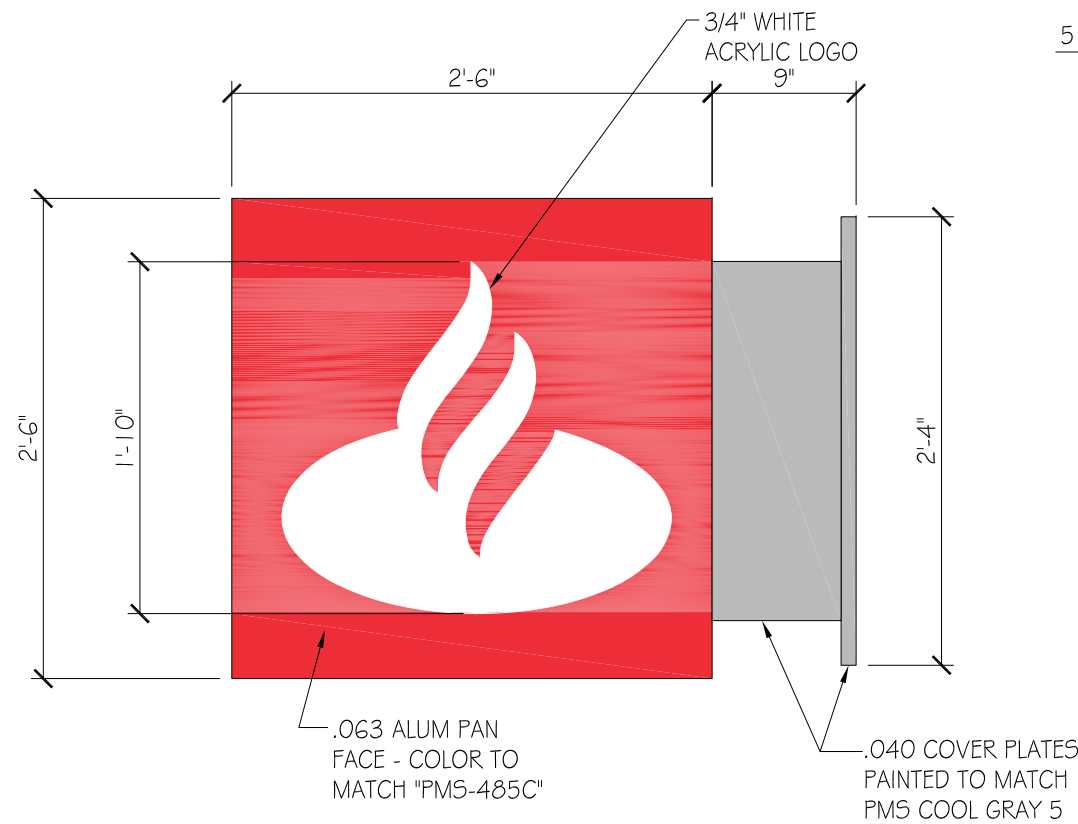

ELEVATION
SCALE: 1" = 1'-0"

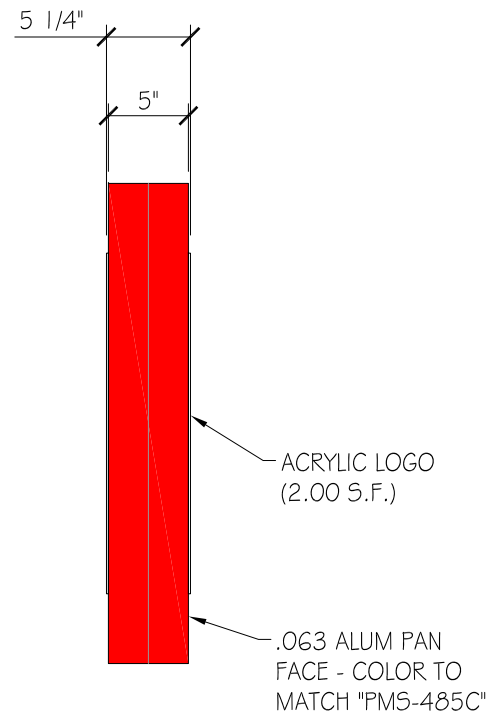

END VIEW
SCALE: 1" = 1'-0"

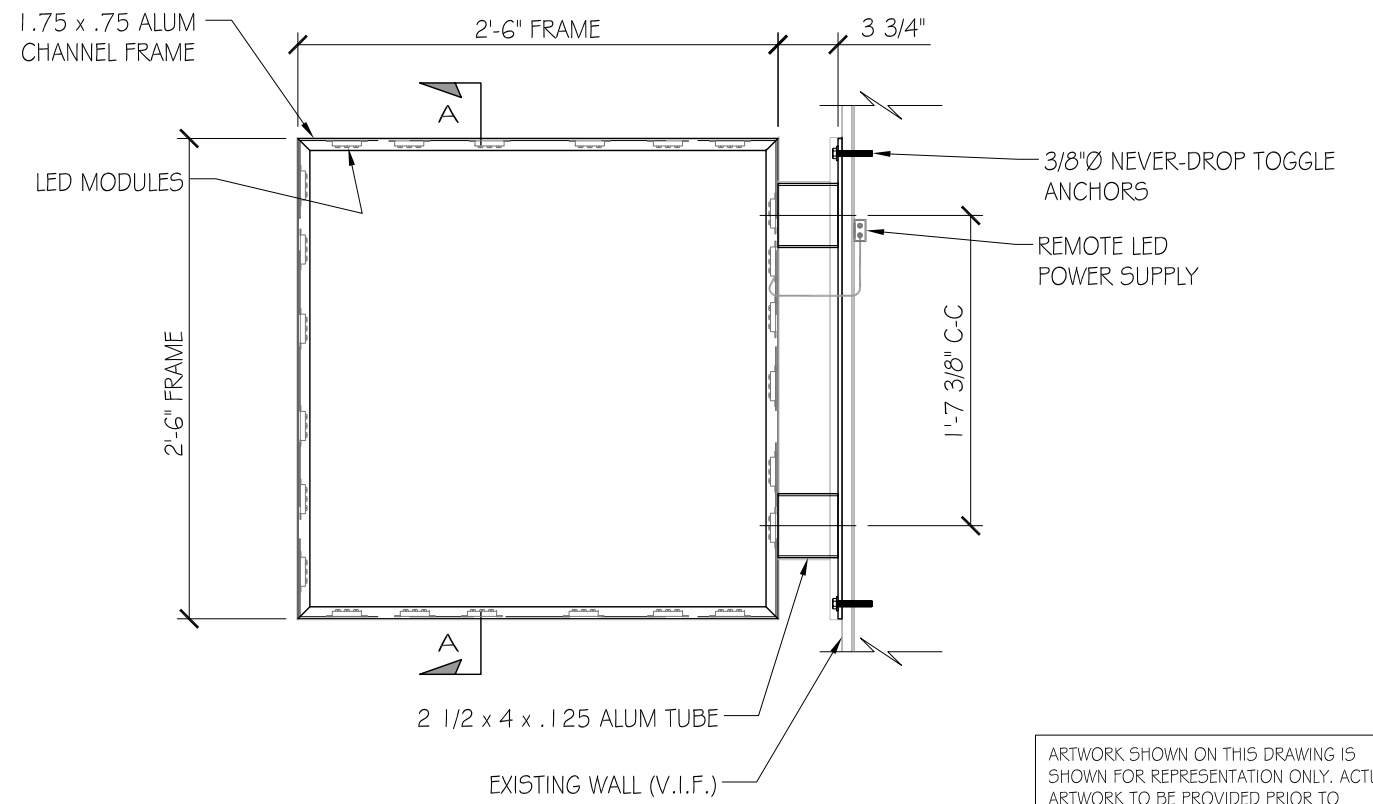

FRAMING DETAIL
SCALE: 1" = 1'-0"

ARTWORK SHOWN ON THIS DRAWING IS SHOWN FOR REPRESENTATION ONLY. ACTUAL ARTWORK TO BE PROVIDED PRIOR TO FABRICATION

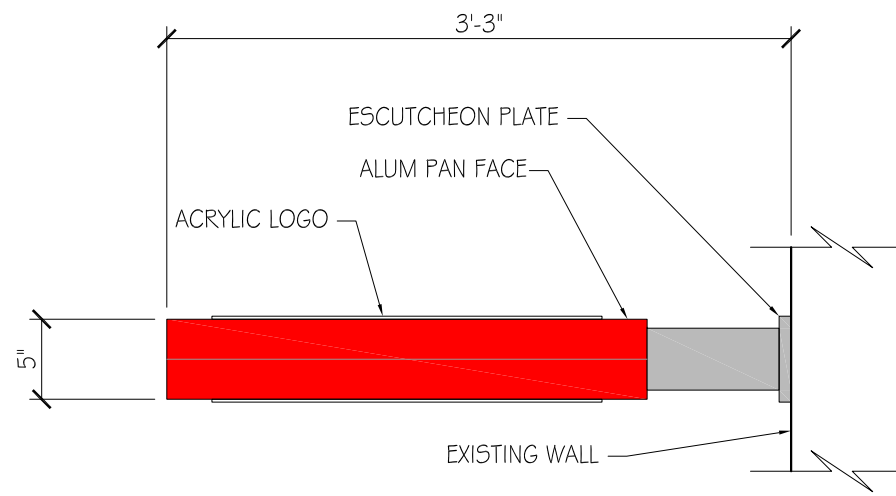

PLAN VIEW
SCALE: 1" = 1'-0"

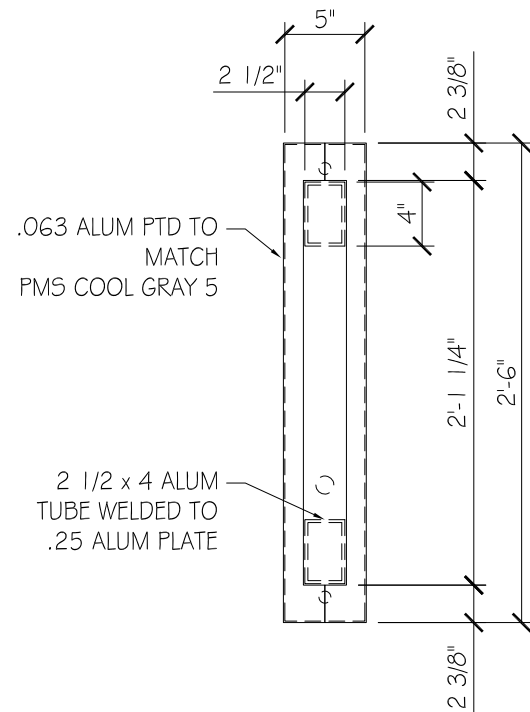

ESCUTCHEON PLATE
SCALE: 1" = 1'-0"

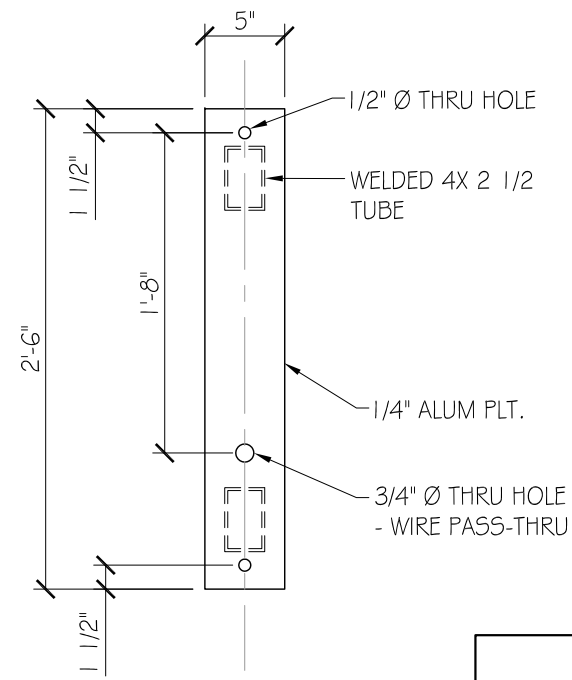

MTG. PLATE
SCALE: 1" = 1'-0"

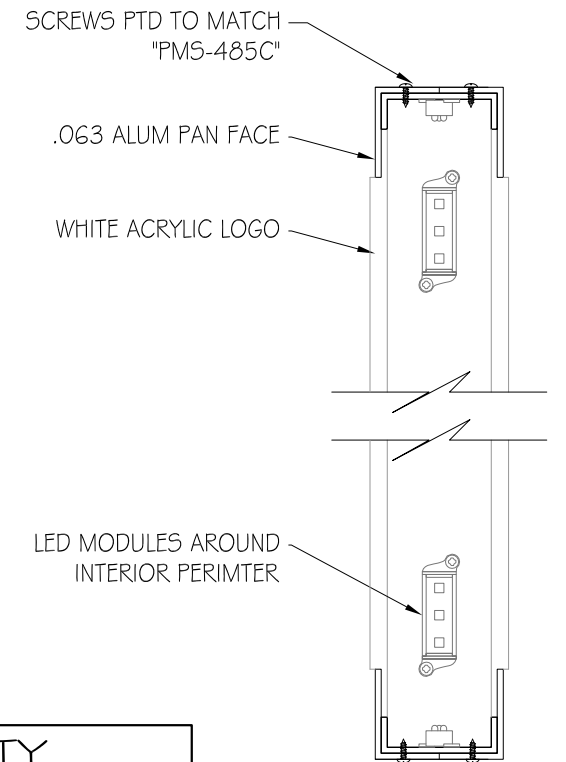

SECTION A-A
SCALE: 1 1/2" = 1'-0"

ELECTRICAL LOAD
.30 AMPS @ 120 VOLTS
ELECTRICAL REQMTS
(1) 20 AMP CIRCUIT

U.L. NOTE
THIS SIGN IS INTENDED TO BE INSTALLED IN ACCORDANCE WITH THE REQUIREMENTS OF ARTICLE 600 OF THE NATIONAL ELECTRICAL CODE AND/OR OTHER APPLICABLE LOCAL CODES. THIS INCLUDES PROPER GROUNDING AND BONDING OF THE SIGN.

QTY
(1) REQUIRED
(SEE SHEET 2.0 FOR LOCATION ON BUILDING)



677 Dunksferry Road Bensalem, PA 19020 | 978 S. Camino Oro Drive Goodyear, AZ 85338
(215) 826-0880 | (215) 826-0514 | www.i1ind.com

DESIGN AND CONSTRUCTION DOCUMENTS AS INSTRUMENTS OF SERVICE ARE GIVEN IN CONFIDENCE AND REMAIN THE PROPERTY OF IMAGE ONE IND. THE USE OF THIS DESIGN AND CONSTRUCTION DOCUMENTS FOR PURPOSES OTHER THAN THE SPECIFIC PROJECT NAMED HERE IN IS STRICTLY PROHIBITED WITHOUT THE EXPRESS WRITTEN CONSENT OF IMAGE ONE INDUSTRIES.

REVISIONS			
REV	DATE	DESCRIPTION	BY



DRAWN BY: LR | DATE: 05.20.19
LOCATION: STORE# 612 | 346 CONGRESS ST. | BOSTON, MA. 02210

JOB #: 12-654 | SCALE: AS NOTED
DRAWING TITLE: DIFF. ILLUM. BLADE SIGN ELEVATIONS, SECTIONS & DETAILS

DRAWING NUMBER: 12654-2.2