

CURRENT DOOR



PROPOSED NEW DOOR



New door would be stained to match current color

Glass on new door would be plain, as on current door, not with stained glass effect

Frame paint would match current color

Door handle would match current style

Metal frame at bottom of current door would be transitioned to new door

Local renovation vendors were contacted and repairing the door is not a feasible option.

CURRENT DOOR - DAMAGE 1

















CAD Drawing

Quote # SEQF000058_1

BRIDGEWATER WHOLESALERS - MA
248 INDUSTRIAL PARKWAY
LEOMINSTER, MA 01453



ROGUE VALLEY
Door

Entered By: Brittany Gaudette bgaudette@bwimillwork.com

7/9/2018

LN	Thick	Width	Height	Pttn	Stile	Top	Btm	Panel	Species	Qty
1	1-3/4	3/0	6/11- 1/4	4060	5-1/4	5	9 1/8	1-3/8 HRP	DF	1

Mod Ovolo Sticking, Newport B, Door Model - 4060, Moulding PM1 - 2 Sides Around Glass Only, Caming Color Brass, Glass Thickness 5/8", Stile and Rail Dimensions Includes 1/2" Sticking Width, Standard Lead-Time

LAVALLEY

CAD Drawing

Quote # SEQF000058_1

BRIDGEWATER WHOLESALERS - MA
248 INDUSTRIAL PARKWAY
LEOMINSTER, MA 01453



Entered By: Brittany Gaudette bgaudette@bwimillwork.com

ROGUE VALLEY
Door

7/9/2018

Door Info

Thickness	1-3/4
Pattern	4060
Species	DF
Width	3/0
Height	6/11-1/4
Stile	5-1/4
Sticking	Mod Ovolo Sticking
Top Rail	5
Bottom Rail	9 1/8
Glass Type	Newport B
Panel Type	1-3/8 HRP
Rogue Premium	

Additional Details

Door Model - 4060, Moulding PM1 - 2
Sides Around Glass Only, Caming
Color Brass, Glass Thickness 5/8",
Stile and Rail Dimensions Includes 1/2"
Sticking Width, Standard Lead-Time

\$1495.00

Name : TOD

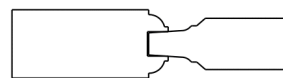
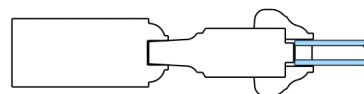
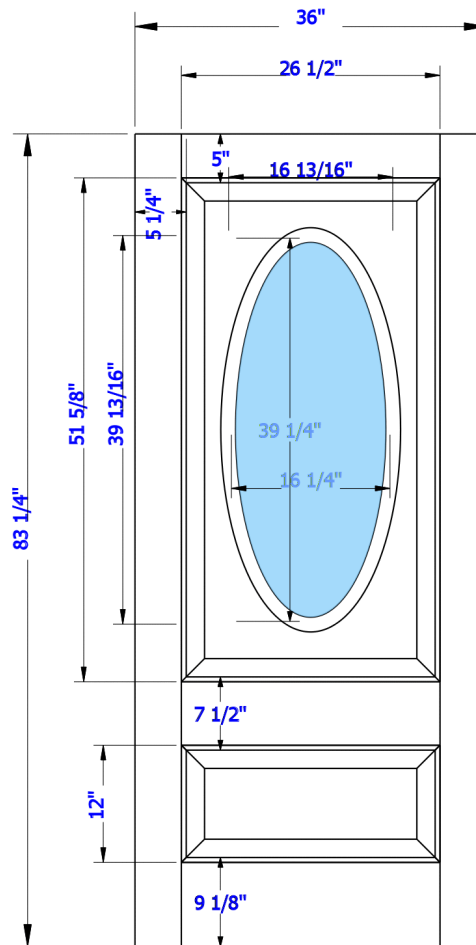

P-322664-1

All images are interior view

Est Weight: 97

LAVALLEY

BWI-M

Page 2 of 2



APPLICATION
CERTIFICATE of APPROPRIATENESS-or-
DESIGN APPROVAL-or-EXEMPTION

Deliver or mail to:
Environment Department
Boston City Hall, Rm 709
Boston, MA 02201

For Office Use Only

APPLICATION # _____
RECEIVED _____
FEE _____
HEARING DATE _____

DO NOT RETURN THIS FORM BY FAX OR EMAIL

DO NOT STAMP THIS BOX

I. PROPERTY ADDRESS 69 Saint Botolph Street, Boston, MA
NAME of BUSINESS/PROPERTY _____

The names, telephone numbers, postal and e-mail addresses requested below will be used for all subsequent communications relating to this application. Environment Department personnel cannot be responsible for illegible, incomplete or inaccurate contact information provided by applicants.

II. APPLICANT Laura van Rooyen
CONTACT NAME Laura RELATIONSHIP TO PROPERTY owner, HOA president
MAILING ADDRESS 69 St Botolph St, Apt 3, Boston, MA ZIP 02116
PHONE 507-254-3015 EMAIL alurame@gmail.com
PROPERTY OWNER 69 Saint Botolph St Trust CONTACT NAME Laura van Rooyen
MAILING ADDRESS 69 St Botolph St, Apt 3, Boston, MA ZIP 02116
PHONE 507-254-3015 EMAIL alurame@gmail.com
ARCHITECT _____ CONTACT NAME _____
MAILING ADDRESS _____ ZIP _____
PHONE _____ EMAIL _____
CONTRACTOR _____ CONTACT NAME _____
MAILING ADDRESS _____ ZIP _____
PHONE _____ EMAIL _____

III. DESCRIPTION OF PROPOSED WORK

A BRIEF OUTLINE OF THE PROPOSED WORK **MUST BE GIVEN IN THE SPACE PROVIDED BELOW, OR THE APPLICATION WILL NOT BE ACCEPTED.** This description provides the basis for the official notice and subsequent decision, and it must clearly represent the entirety of the project. Additional pages may be attached, if necessary, to provide more detailed information.

Front door and door frame are worn down and warping from years of exposure to weather elements; door was also damaged recently by an attempted break-in. We would like to replace the door and refinish the door frame to restore the look of our building. HOA approved project, awaiting Environment Department approval of this application.

REQUIRED DOCUMENTATION: Please include all required documentation with this application; review instructions carefully for details.

ESTIMATED COST OF PROPOSED WORK: \$2,000

IV. DULY AUTHORIZED SIGNATURES (both required)

The facts set forth above in this application and accompanying documents are a true statement made under penalty of perjury.

APPLICANT Laura E. van Rooyen OWNER* Laura E. van Rooyen
 *(If building is a condominium or cooperative, the chairman must sign.)

PRINT Laura E. van Rooyen PRINT Laura E van Rooyen

Environment Department personnel cannot be responsible for verifying the authority of the above individuals to sign this application. Misrepresentation of signatory authority may result in the invalidation of the application.

UNSIGNED OR PARTIALLY SIGNED FORMS WILL BE REJECTED

THIS APPLICATION IS NOT COMPLETE WITHOUT SIGNATURES, FEES AND REQUIRED DOCUMENTATION.

The checklist below is for reference only: Please refer to the detailed application instructions for deadlines, fee schedule and required documentation specific to your proposal.

- COMPLETED APPLICATION FORM
- APPLICATION FEE (Check or money order made payable to City of Boston; see fee schedule in Instructions)
- DESCRIPTION OF WORK (A brief description must be included on the front page; additional pages of detailed information may be attached. **Applications that only note "see attached" will not be accepted.**)
- PHOTOS OF EXISTING CONDITIONS
- DRAWINGS AND SPECIFICATIONS AS REQUIRED (See "documentation requirements" in instructions)