

Tremont Pl.

Tremont St.

Tremont St.

Tremont St.

Tremont St.

Park Street Church

Boston Athenaeum

Section A  
Section B  
Section C  
Section D

CITY OF BOSTON  
GRANARY BURYING  
GROUND  
TREMONT ST. BOSTON, MASS.

Map updated in 2014 by the  
Historic Burying Grounds Initiative

This version may differ slightly from  
the original.

SCALE: 5 FEET TO AN INCH

UNCLERED BURIALS (INDICATED BY STAR)  
UNCLERED BURIALS (INDICATED BY SQUARE)  
UNCLERED BURIALS (INDICATED BY TRIANGLE)  
UNCLERED BURIALS (INDICATED BY CIRCLE)

SECTION LOCATIONS AND DATES  
Section A: 1670-1850  
Section B: 1670-1850  
Section C: 1670-1850  
Section D: 1670-1850

Section C: Burial of Mary...  
Section C: Burial of...  
Section C: Burial of...

Section D: Burial of...

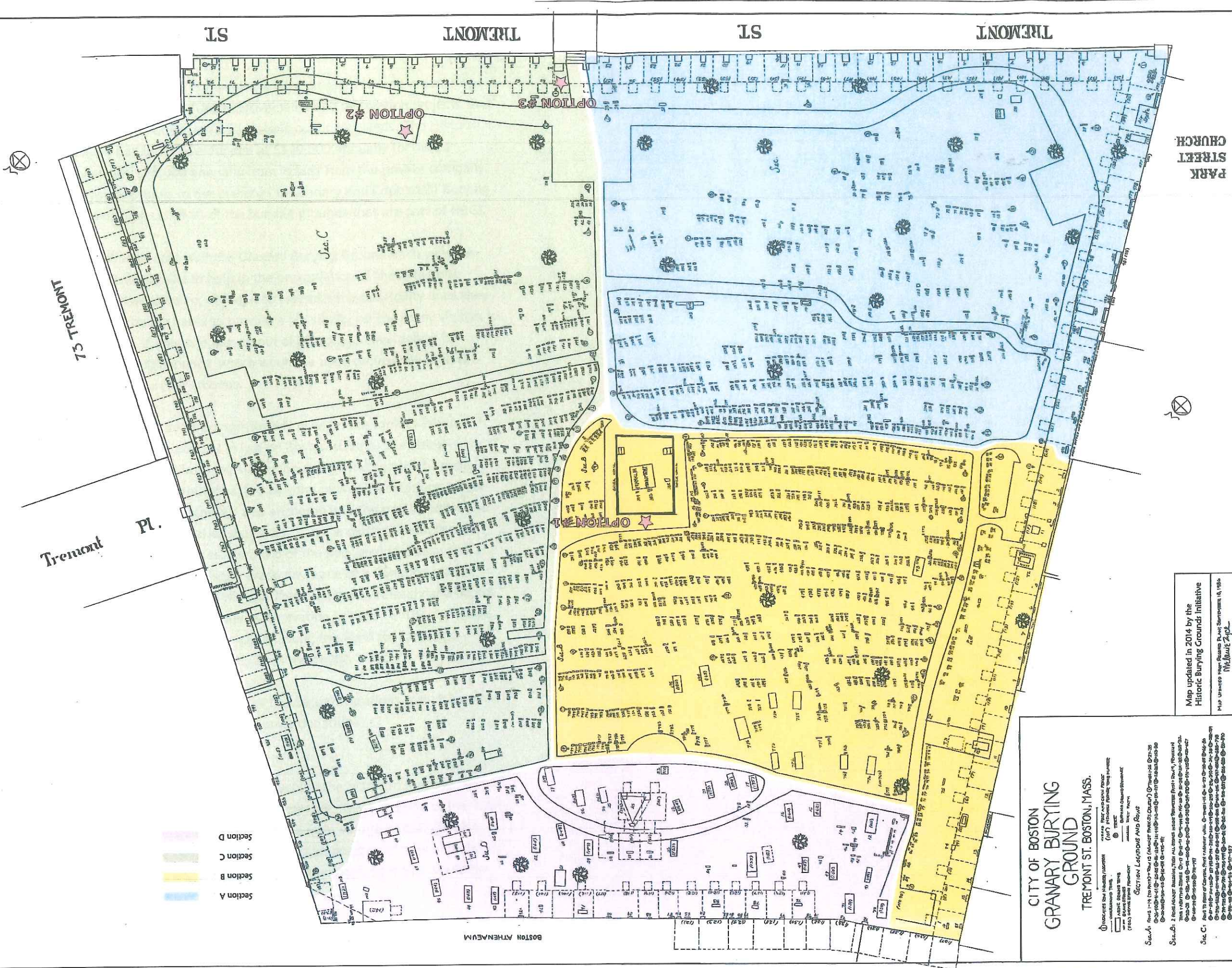

- Section A
- Section B
- Section C
- Section D

**CITY OF BOSTON  
GRANARY BURYING  
GROUND  
TREMONT ST, BOSTON, MASS.**

- ⊠ UNREGISTERED BURIALS/INTERMENTS
  - ⊠ REGISTERED BURIALS/INTERMENTS
  - ⊠ INTERMENTS IN TRANSIT
  - ⊠ BURIALS IN TRANSIT
  - ⊠ BURIALS UNDERWAY
- SECTION LOCATIONS AND ROLES
  - Section A: 1.5 Acre Burial Plot (1870-1920) (Section A) @ 0435-03-01-02-03-04-05-06-07-08-09-10-11-12-13-14-15-16-17-18-19-20-21-22-23-24-25-26-27-28-29-30-31-32-33-34-35-36-37-38-39-40-41-42-43-44-45-46-47-48-49-50-51-52-53-54-55-56-57-58-59-60-61-62-63-64-65-66-67-68-69-70-71-72-73-74-75-76-77-78-79-80-81-82-83-84-85-86-87-88-89-90-91-92-93-94-95-96-97-98-99-100-101-102-103-104-105-106-107-108-109-110-111-112-113-114-115-116-117-118-119-120-121-122-123-124-125-126-127-128-129-130-131-132-133-134-135-136-137-138-139-140-141-142-143-144-145-146-147-148-149-150-151-152-153-154-155-156-157-158-159-160-161-162-163-164-165-166-167-168-169-170-171-172-173-174-175-176-177-178-179-180-181-182-183-184-185-186-187-188-189-190-191-192-193-194-195-196-197-198-199-200-201-202-203-204-205-206-207-208-209-210-211-212-213-214-215-216-217-218-219-220-221-222-223-224-225-226-227-228-229-230-231-232-233-234-235-236-237-238-239-240-241-242-243-244-245-246-247-248-249-250-251-252-253-254-255-256-257-258-259-260-261-262-263-264-265-266-267-268-269-270-271-272-273-274-275-276-277-278-279-280-281-282-283-284-285-286-287-288-289-290-291-292-293-294-295-296-297-298-299-300-301-302-303-304-305-306-307-308-309-310-311-312-313-314-315-316-317-318-319-320-321-322-323-324-325-326-327-328-329-330-331-332-333-334-335-336-337-338-339-340-341-342-343-344-345-346-347-348-349-350-351-352-353-354-355-356-357-358-359-360-361-362-363-364-365-366-367-368-369-370-371-372-373-374-375-376-377-378-379-380-381-382-383-384-385-386-387-388-389-390-391-392-393-394-395-396-397-398-399-400-401-402-403-404-405-406-407-408-409-410-411-412-413-414-415-416-417-418-419-420-421-422-423-424-425-426-427-428-429-430-431-432-433-434-435-436-437-438-439-440-441-442-443-444-445-446-447-448-449-450-451-452-453-454-455-456-457-458-459-460-461-462-463-464-465-466-467-468-469-470-471-472-473-474-475-476-477-478-479-480-481-482-483-484-485-486-487-488-489-490-491-492-493-494-495-496-497-498-499-500-501-502-503-504-505-506-507-508-509-510-511-512-513-514-515-516-517-518-519-520-521-522-523-524-525-526-527-528-529-530-531-532-533-534-535-536-537-538-539-540-541-542-543-544-545-546-547-548-549-550-551-552-553-554-555-556-557-558-559-560-561-562-563-564-565-566-567-568-569-570-571-572-573-574-575-576-577-578-579-580-581-582-583-584-585-586-587-588-589-590-591-592-593-594-595-596-597-598-599-600-601-602-603-604-605-606-607-608-609-610-611-612-613-614-615-616-617-618-619-620-621-622-623-624-625-626-627-628-629-630-631-632-633-634-635-636-637-638-639-640-641-642-643-644-645-646-647-648-649-650-651-652-653-654-655-656-657-658-659-660-661-662-663-664-665-666-667-668-669-670-671-672-673-674-675-676-677-678-679-680-681-682-683-684-685-686-687-688-689-690-691-692-693-694-695-696-697-698-699-700-701-702-703-704-705-706-707-708-709-710-711-712-713-714-715-716-717-718-719-720-721-722-723-724-725-726-727-728-729-730-731-732-733-734-735-736-737-738-739-740-741-742-743-744-745-746-747-748-749-750-751-752-753-754-755-756-757-758-759-760-761-762-763-764-765-766-767-768-769-770-771-772-773-774-775-776-777-778-779-780-781-782-783-784-785-786-787-788-789-790-791-792-793-794-795-796-797-798-799-800-801-802-803-804-805-806-807-808-809-810-811-812-813-814-815-816-817-818-819-820-821-822-823-824-825-826-827-828-829-830-831-832-833-834-835-836-837-838-839-840-841-842-843-844-845-846-847-848-849-850-851-852-853-854-855-856-857-858-859-860-861-862-863-864-865-866-867-868-869-870-871-872-873-874-875-876-877-878-879-880-881-882-883-884-885-886-887-888-889-890-891-892-893-894-895-896-897-898-899-900-901-902-903-904-905-906-907-908-909-910-911-912-913-914-915-916-917-918-919-920-921-922-923-924-925-926-927-928-929-930-931-932-933-934-935-936-937-938-939-940-941-942-943-944-945-946-947-948-949-950-951-952-953-954-955-956-957-958-959-960-961-962-963-964-965-966-967-968-969-970-971-972-973-974-975-976-977-978-979-980-981-982-983-984-985-986-987-988-989-990-991-992-993-994-995-996-997-998-999-1000-1001-1002-1003-1004-1005-1006-1007-1008-1009-1010-1011-1012-1013-1014-1015-1016-1017-1018-1019-1020-1021-1022-1023-1024-1025-1026-1027-1028-1029-1030-1031-1032-1033-1034-1035-1036-1037-1038-1039-1040-1041-1042-1043-1044-1045-1046-1047-1048-1049-1050-1051-1052-1053-1054-1055-1056-1057-1058-1059-1060-1061-1062-1063-1064-1065-1066-1067-1068-1069-1070-1071-1072-1073-1074-1075-1076-1077-1078-1079-1080-1081-1082-1083-1084-1085-1086-1087-1088-1089-1090-1091-1092-1093-1094-1095-1096-1097-1098-1099-1100-1101-1102-1103-1104-1105-1106-1107-1108-1109-1110-1111-1112-1113-1114-1115-1116-1117-1118-1119-1120-1121-1122-1123-1124-1125-1126-1127-1128-1129-1130-1131-1132-1133-1134-1135-1136-1137-1138-1139-1140-1141-1142-1143-1144-1145-1146-1147-1148-1149-1150-1151-1152-1153-1154-1155-1156-1157-1158-1159-1160-1161-1162-1163-1164-1165-1166-1167-1168-1169-1170-1171-1172-1173-1174-1175-1176-1177-1178-1179-1180-1181-1182-1183-1184-1185-1186-1187-1188-1189-1190-1191-1192-1193-1194-1195-1196-1197-1198-1199-1200-1201-1202-1203-1204-1205-1206-1207-1208-1209-1210-1211-1212-1213-1214-1215-1216-1217-1218-1219-1220-1221-1222-1223-1224-1225-1226-1227-1228-1229-1230-1231-1232-1233-1234-1235-1236-1237-1238-1239-1240-1241-1242-1243-1244-1245-1246-1247-1248-1249-1250-1251-1252-1253-1254-1255-1256-1257-1258-1259-1260-1261-1262-1263-1264-1265-1266-1267-1268-1269-1270-1271-1272-1273-1274-1275-1276-1277-1278-1279-1280-1281-1282-1283-1284-1285-1286-1287-1288-1289-1290-1291-1292-1293-1294-1295-1296-1297-1298-1299-1300-1301-1302-1303-1304-1305-1306-1307-1308-1309-1310-1311-1312-1313-1314-1315-1316-1317-1318-1319-1320-1321-1322-1323-1324-1325-1326-1327-1328-1329-1330-1331-1332-1333-1334-1335-1336-1337-1338-1339-1340-1341-1342-1343-1344-1345-1346-1347-1348-1349-1350-1351-1352-1353-1354-1355-1356-1357-1358-1359-1360-1361-1362-1363-1364-1365-1366-1367-1368-1369-1370-1371-1372-1373-1374-1375-1376-1377-1378-1379-1380-1381-1382-1383-1384-1385-1386-1387-1388-1389-1390-1391-1392-1393-1394-1395-1396-1397-1398-1399-1400-1401-1402-1403-1404-1405-1406-1407-1408-1409-1410-1411-1412-1413-1414-1415-1416-1417-1418-1419-1420-1421-1422-1423-1424-1425-1426-1427-1428-1429-1430-1431-1432-1433-1434-1435-1436-1437-1438-1439-1440-1441-1442-1443-1444-1445-1446-1447-1448-1449-1450-1451-1452-1453-1454-1455-1456-1457-1458-1459-1460-1461-1462-1463-1464-1465-1466-1467-1468-1469-1470-1471-1472-1473-1474-1475-1476-1477-1478-1479-1480-1481-1482-1483-1484-1485-1486-1487-1488-1489-1490-1491-1492-1493-1494-1495-1496-1497-1498-1499-1500-1501-1502-1503-1504-1505-1506-1507-1508-1509-1510-1511-1512-1513-1514-1515-1516-1517-1518-1519-1520-1521-1522-1523-1524-1525-1526-1527-1528-1529-1530-1531-1532-1533-1534-1535-1536-1537-1538-1539-1540-1541-1542-1543-1544-1545-1546-1547-1548-1549-1550-1551-1552-1553-1554-1555-1556-1557-1558-1559-1560-1561-1562-1563-1564-1565-1566-1567-1568-1569-1570-1571-1572-1573-1574-1575-1576-1577-1578-1579-1580-1581-1582-1583-1584-1585-1586-1587-1588-1589-1590-1591-1592-1593-1594-1595-1596-1597-1598-1599-1600-1601-1602-1603-1604-1605-1606-1607-1608-1609-1610-1611-1612-1613-1614-1615-1616-1617-1618-1619-1620-1621-1622-1623-1624-1625-1626-1627-1628-1629-1630-1631-1632-1633-1634-1635-1636-1637-1638-1639-1640-1641-1642-1643-1644-1645-1646-1647-1648-1649-1650-1651-1652-1653-1654-1655-1656-1657-1658-1659-1660-1661-1662-1663-1664-1665-1666-1667-1668-1669-1670-1671-1672-1673-1674-1675-1676-1677-1678-1679-1680-1681-1682-1683-1684-1685-1686-1687-1688-1689-1690-1691-1692-1693-1694-1695-1696-1697-1698-1699-1700-1701-1702-1703-1704-1705-1706-1707-1708-1709-1710-1711-1712-1713-1714-1715-1716-1717-1718-1719-1720-1721-1722-1723-1724-1725-1726-1727-1728-1729-1730-1731-1732-1733-1734-1735-1736-1737-1738-1739-1740-1741-1742-1743-1744-1745-1746-1747-1748-1749-1750-1751-1752-1753-1754-1755-1756-1757-1758-1759-1760-1761-1762-1763-1764-1765-1766-1767-1768-1769-1770-1771-1772-1773-1774-1775-1776-1777-1778-1779-1780-1781-1782-1783-1784-1785-1786-1787-1788-1789-1790-1791-1792-1793-1794-1795-1796-1797-1798-1799-1800-1801-1802-1803-1804-1805-1806-1807-1808-1809-1810-1811-1812-1813-1814-1815-1816-1817-1818-1819-1820-1821-1822-1823-1824-1825-1826-1827-1828-1829-1830-1831-1832-1833-1834-1835-1836-1837-1838-1839-1840-1841-1842-1843-1844-1845-1846-1847-1848-1849-1850-1851-1852-1853-1854-1855-1856-1857-1858-1859-1860-1861-1862-1863-1864-1865-1866-1867-1868-1869-1870-1871-1872-1873-1874-1875-1876-1877-1878-1879-1880-1881-1882-1883-1884-1885-1886-1887-1888-1889-1890-1891-1892-1893-1894-1895-1896-1897-1898-1899-1900-1901-1902-1903-1904-1905-1906-1907-1908-1909-1910-1911-1912-1913-1914-1915-1916-1917-1918-1919-1920-1921-1922-1923-1924-1925-1926-1927-1928-1929-1930-1931-1932-1933-1934-1935-1936-1937-1938-1939-1940-1941-1942-1943-1944-1945-1946-1947-1948-1949-1950-1951-1952-1953-1954-1955-1956-1957-1958-1959-1960-1961-1962-1963-1964-1965-1966-1967-1968-1969-1970-1971-1972-1973-1974-1975-1976-1977-1978-1979-1980-1981-1982-1983-1984-1985-1986-1987-1988-1989-1990-1991-1992-1993-1994-1995-1996-1997-1998-1999-2000-2001-2002-2003-2004-2005-2006-2007-2008-2009-2010-2011-2012-2013-2014-2015-2016-2017-2018-2019-2020-2021-2022-2023-2024-2025-2026-2027-2028-2029-2030-2031-2032-2033-2034-2035-2036-2037-2038-2039-2040-2041-2042-2043-2044-2045-2046-2047-2048-2049-2050-2051-2052-2053-2054-2055-2056-2057-2058-2059-2060-2061-2062-2063-2064-2065-2066-2067-2068-2069-2070-2071-2072-2073-2074-2075-2076-2077-2078-2079-2080-2081-2082-2083-2084-2085-2086-2087-2088-2089-2090-2091-2092-2093-2094-2095-2096-2097-2098-2099-2100-2101-2102-2103-2104-2105-2106-2107-2108-2109-2110-2111-2112-2113-2114-2115-2116-2117-2118-2119-2120-2121-2122-2123-2124-2125-2126-2127-2128-2129-2130-2131-2132-2133-2134-2135-2136-2137-2138-2139-2140-2141-2142-2143-2144-2145-2146-2147-2148-2149-2150-2151-2152-2153-2154-2155-2156-2157-2158-2159-2160-2161-2162-2163-2164-2165-2166-2167-2168-2169-2170-2171-2172-2173-2174-2175-2176-2177-2178-2179-2180-2181-2182-2183-2184-2185-2186-2187-2188-2189-2190-2191-2192-2193-2194-2195-2196-2197-2198-2199-2200-2201-2202-2203-2204-2205-2206-2207-2208-2209-2210-2211-2212-2213-2214-2215-2216-2217-2218-2219-2220-2221-2222-2223-2224-2225-2226-2227-2228-2229-2230-2231-2232-2233-2234-2235-2236-2237-2238-2239-2240-2241-2242-2243-2244-2245-2246-2247-2248-2249-2250-2251-2252-2253-2254-2255-2256-2257-2258-2259-2260-2261-2262-2263-2264-2265-2266-2267-2268-2269-2270-2271-2272-2273-2274-2275-2276-2277-2278-2279-2280-2281-2282-2283-2284-2285-2286-2287-2288-2289-2290-2291-2292-2293-2294-2295-2296-2297-2298-2299-2300-2301-2302-2303-2304-2305-2306-2307-2308-2309-2310-2311-2312-2313-2314-2315-2316-2317-2318-2319-2320-2321-2322-2323-2324-2325-2326-2327-2328-2329-2330-2331-2332-2333-2334-2335-2336-2337-2338-2339-2340-2341-2342-2343-2344-2345-2346-2347-2348-2349-2350-2351-2352-2353-2354-2355-2356-2357-2358-2359-2360-2361-2362-2363-2364-2365-2366-2367-2368-2369-2370-2371-2372-2373-2374-2375-2376-2377-2378-2379-2380-2381-2382-2383-2384-2385-2386-2387-2388-2389-2390-2391-2392-2393-2394-2395-2396-2397-2398-2399-2400-2401-2402-2403-2404-2405-2406-2407-2408-2409-2410-2411-2412-2413-2414-2415-2416-2417-2418-2419-2420-2421-2422-2423-2424-2425-2426-2427-2428-2429-2430-2431-2432-2433-2434-2435-2436-2437-2438-2439-2440-2441-2442-2443-2444-2445-2446-2447-2448-2449-2450-2451-2452-2453-2454-2455-2456-2457-2458-2459-2460-2461-2462-2463-2464-2465-2466-2467-2468-2469-2470-2471-2472-2473-2474-2475-2476-2477-2478-2479-2480-2481-2482-2483-2484-2485-2486-2487-2488-2489-2490-2491-2492-2493-2494-2495-2496-2497-2498-2499-2500-2501-2502-2503-2504-2505-2506-2507-2508-2509-2510-2511-2512-2513-2514-2515-2516-2517-2518-2519-2520-2521-2522-2523-2524-2525-2526-2527-2528-2529-2530-2531-2532-2533-2534-2535-2536-2537-2538-2539-2540-2541-2542-2543-2544-2545-2546-2547-2548-2549-2550-2551-2552-2553-2554-2555-2556-2557-2558-2559-2560-2561-25

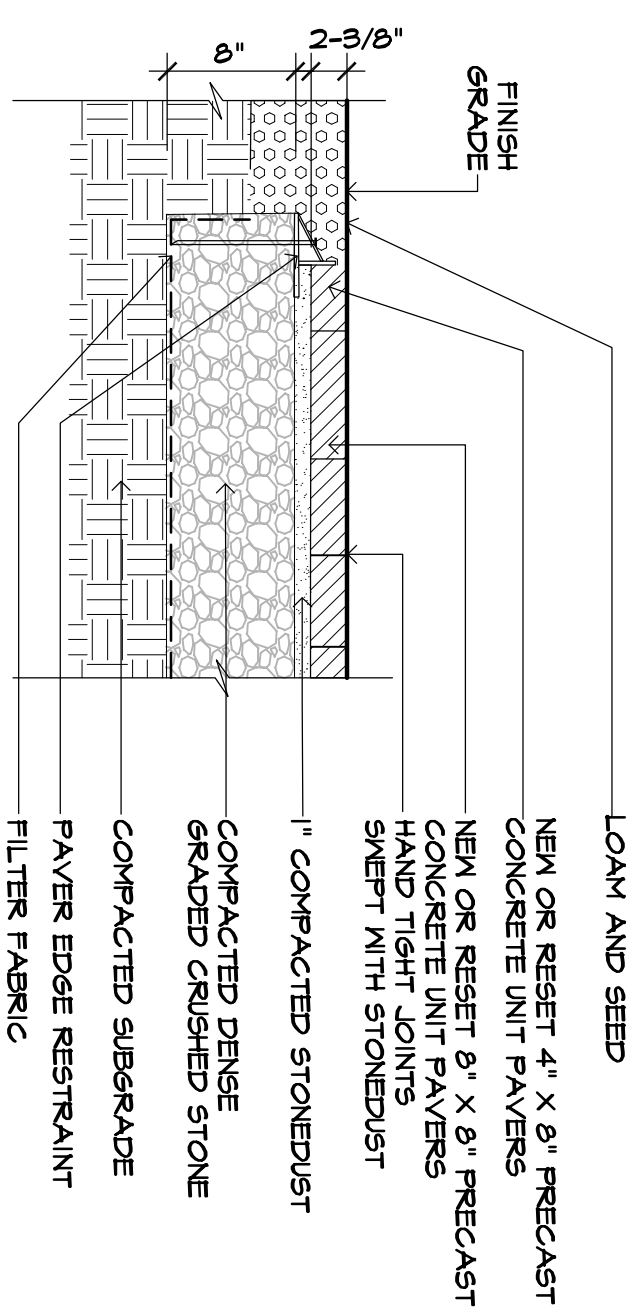

1 UNIT PAVERS - SECTION  
SCALE: 1" = 1'-0"

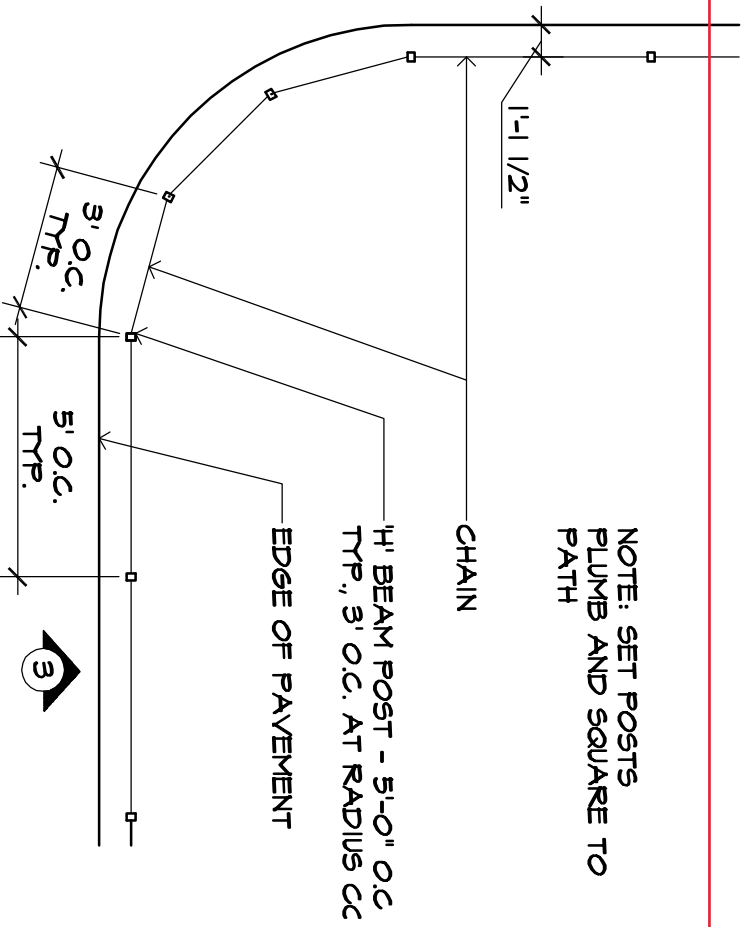

2 POST AND CHAIN LAYOUT - TYPICAL  
SCALE: 1/4" = 1'-0"

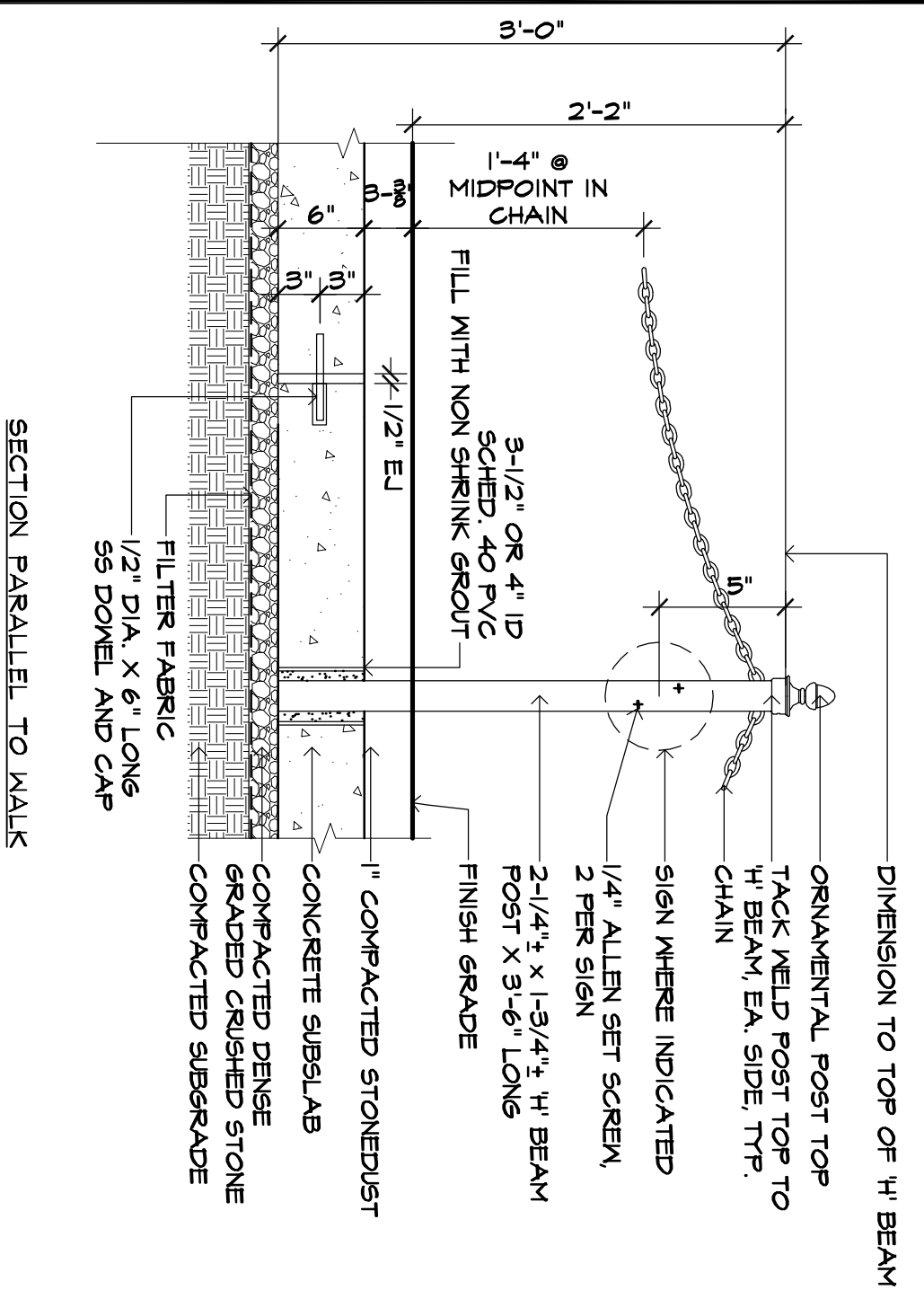

3 POST AND CHAIN - SECTION  
SCALE: 1" = 1'-0"

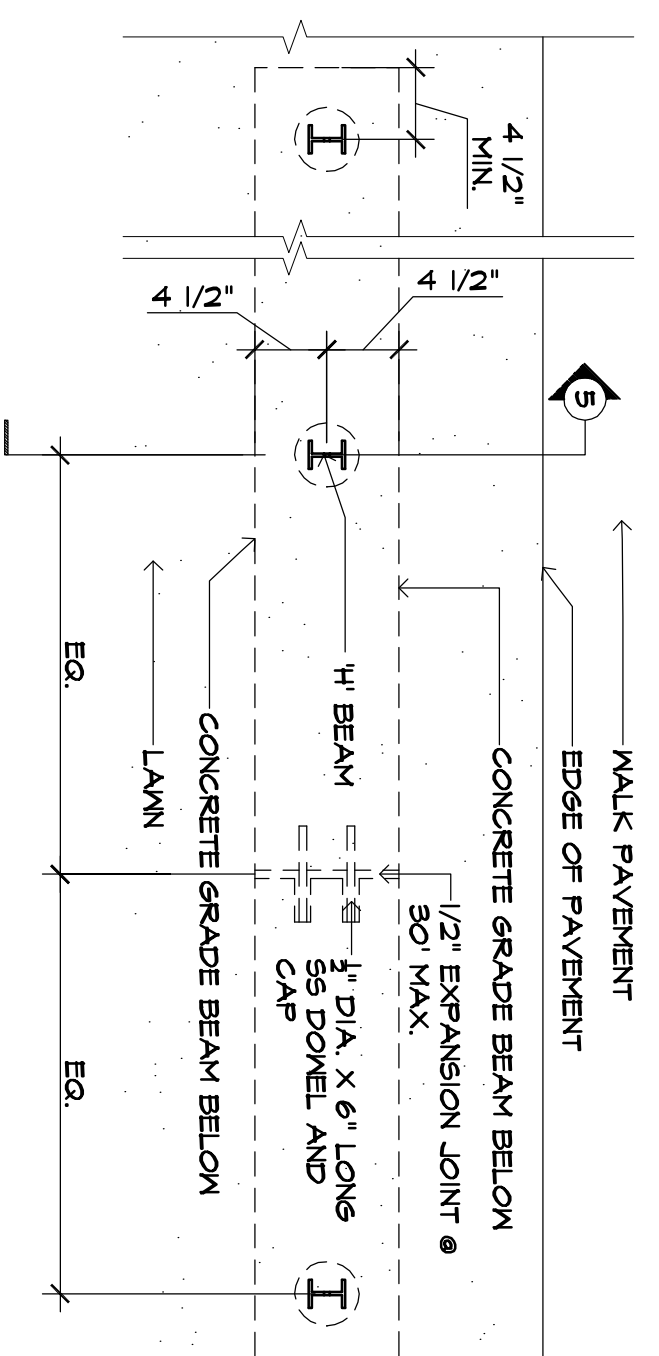
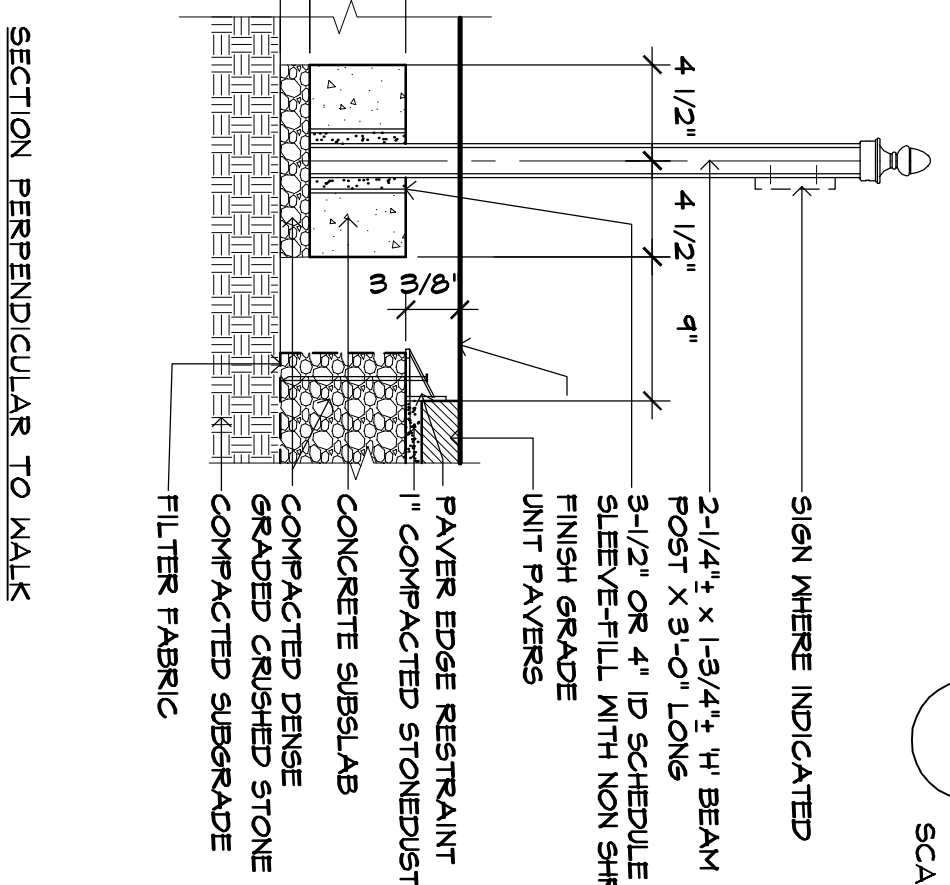

4 POST AND CHAIN - PLAN @ END OF POST AND CHAIN RUN  
SCALE: 1" = 1'-0"

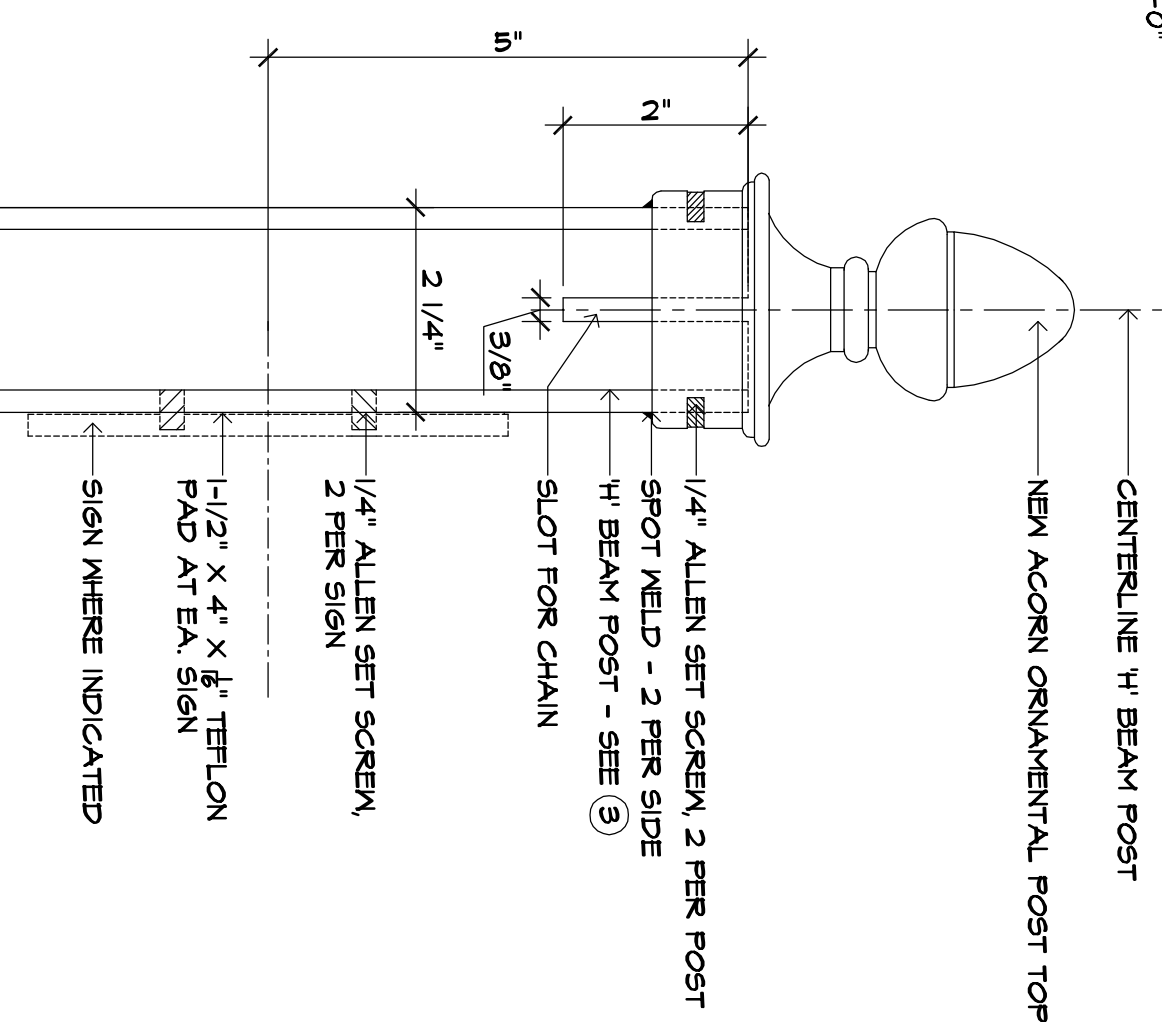

5 ACORN ORNAMENTAL POST TOP DETAIL - ELEVATION  
SCALE: 6" = 1'-0"

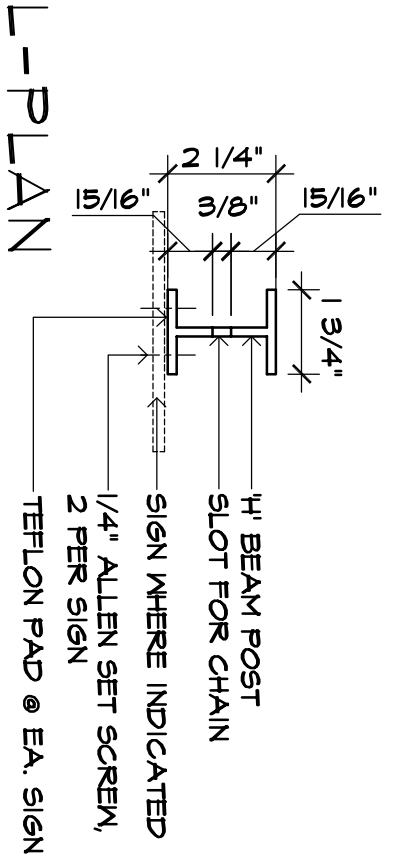

6 POST DETAIL-PLAN  
SCALE: 3" = 1'-0"

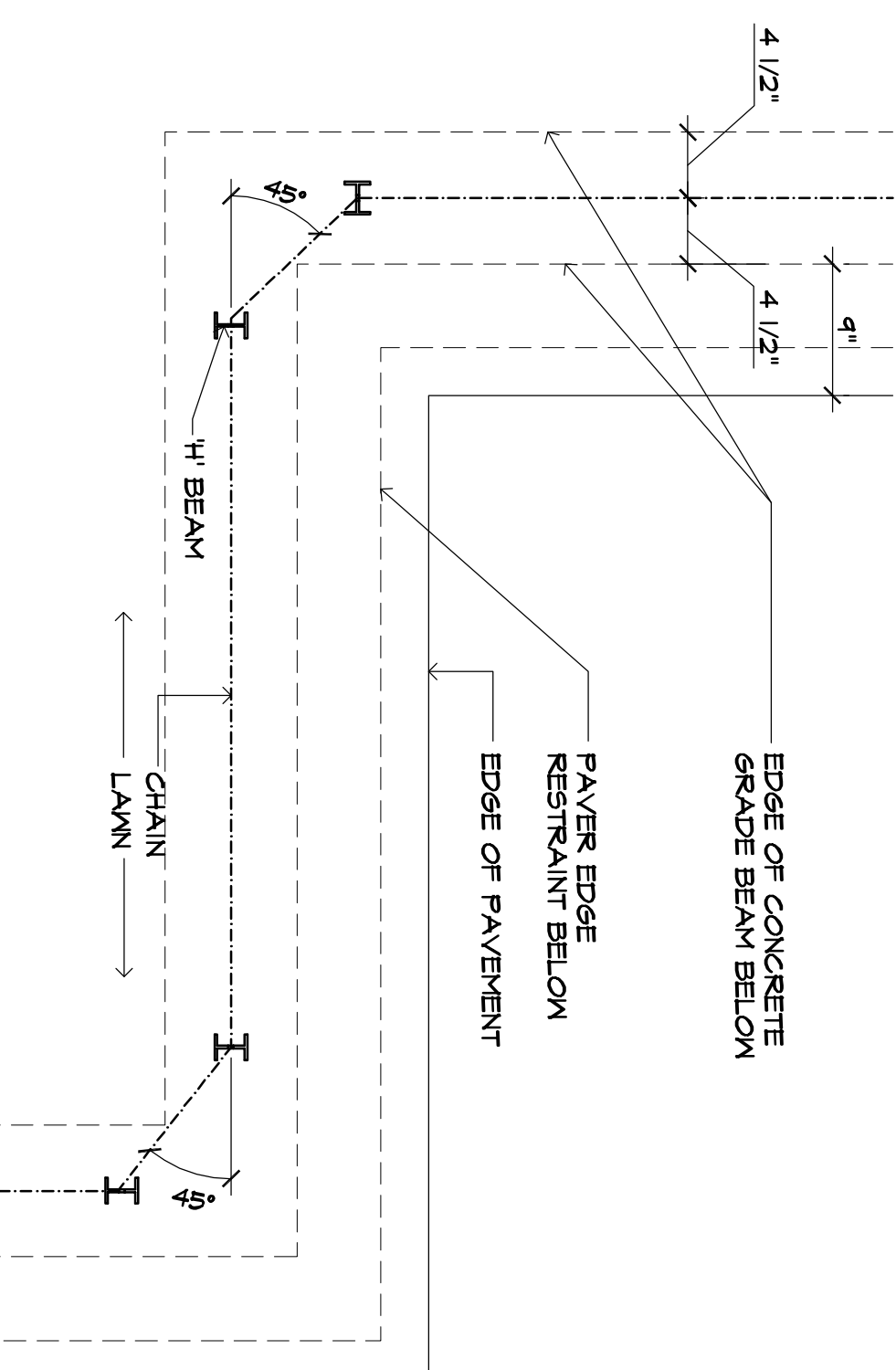

7 POST AND CHAIN - PLAN @ CORNERS  
SCALE: 1" = 1'-0"

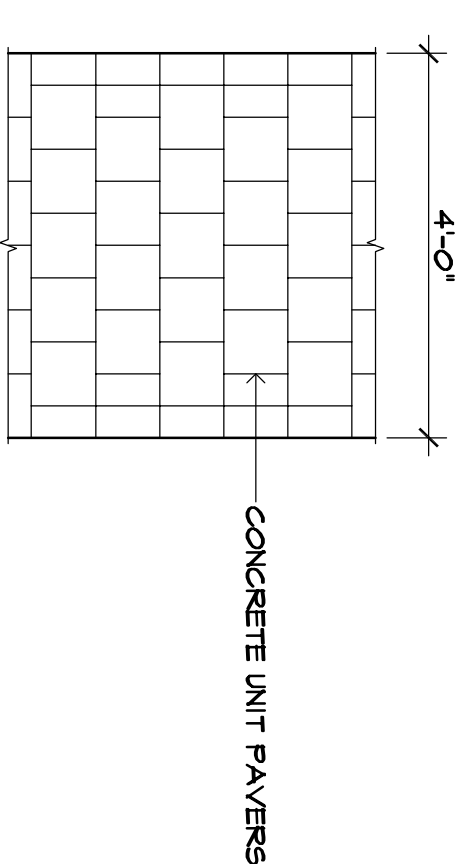

8 TYPICAL PATH PLAN  
SCALE: 1/2" = 1'-0"

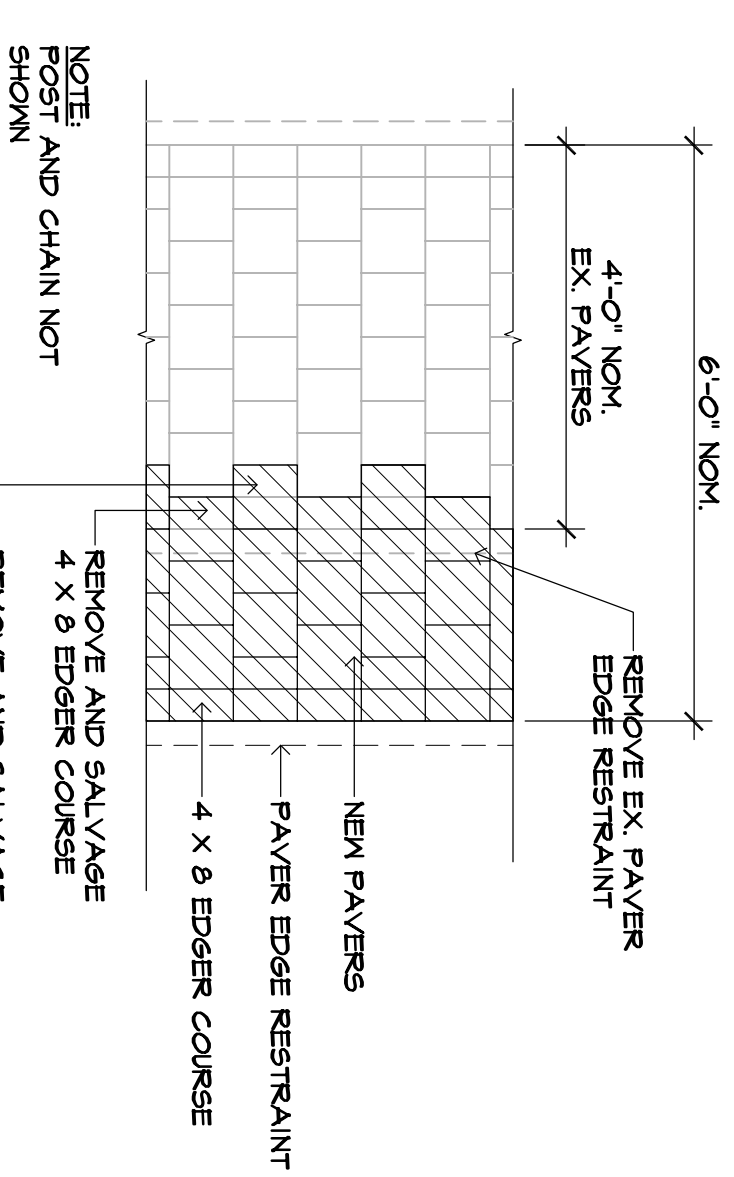

9 TYPICAL PATH PLAN @ WIDENED PATH  
SCALE: 1/2" = 1'-0"

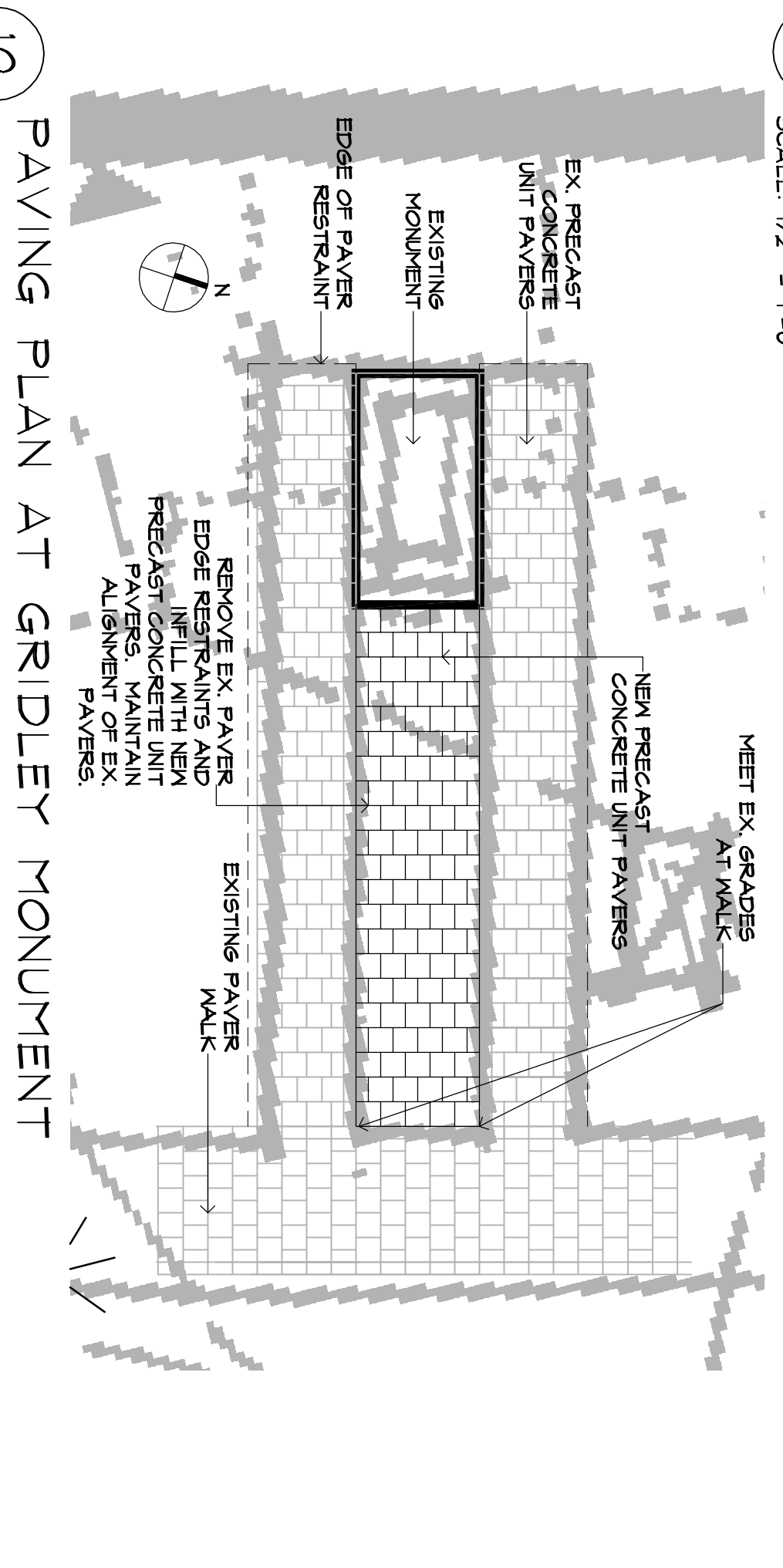

10 PAVING PLAN AT GRIDLEY MONUMENT  
SCALE: 1/4" = 1'-0"

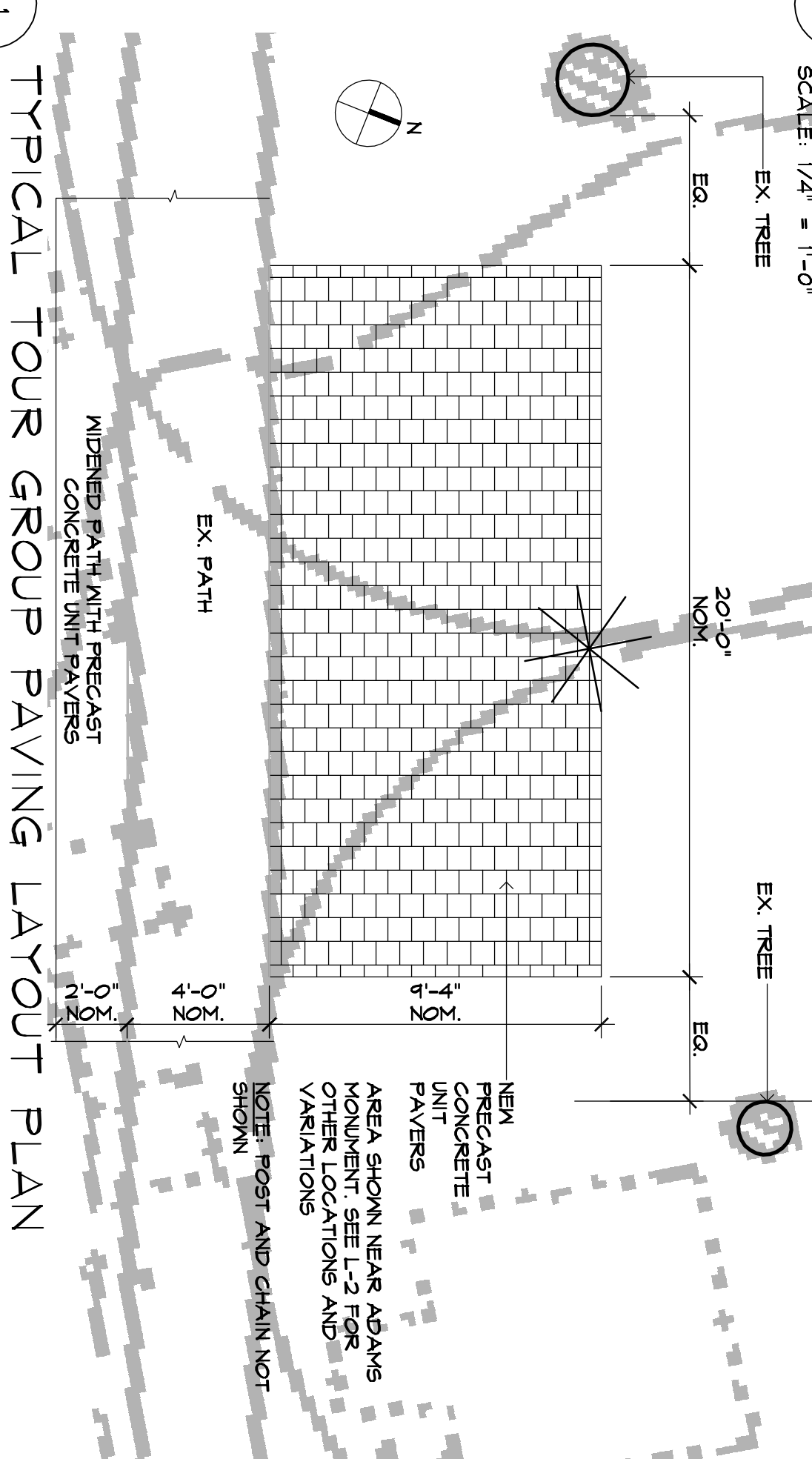

11 TYPICAL TOUR GROUP PAVING LAYOUT PLAN  
SCALE: 1/4" = 1'-0"

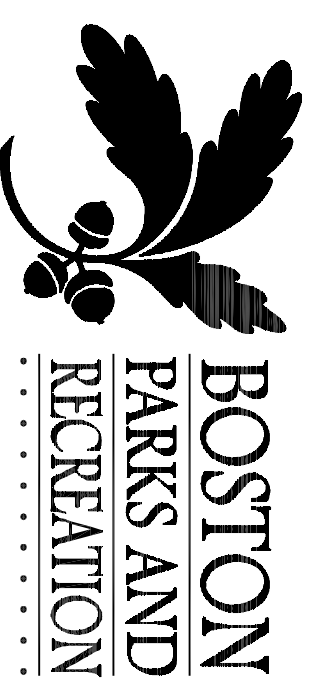

**BOSTON PARKS AND RECREATION**

Prepared By:  
**WALKER-KLUESING DESIGN GROUP**  
129 Waverley Street, Suite 1  
Belmont MA 02478 USA 617-484-8444

Consultant Project No.

PROJECT NO.



No.	Date	Revision

Project Name:

**Granary Burying Ground**  
**Historic Landscape Rehabilitation**  
Boston, Massachusetts

Revised	Project No.	CPK xxxxxx

Sheet Name:

**Site Details**

Sheet No.:

**L-4**

# StradaPAL

Multi-services terminal, running on solar power



Full option  
on solar power

Large  
color screen

Parkeon  
Cloud-system



# StradaPAL

## General design

Anti-corrosive steel

Size: (HxWxD) 65.90" x 18.70" x 14.92" - Ground mounting pedestal permits a variation of terminal height, up to an additional 5.39"

Weight: 198.42 lb

Standard colors:



Temperature - Humidity: -13°F to +131°F / up to 95% relative humidity at 131°F

EN 12414 / CE marking

## User Interface

7" color screen

- 7" LCD TFT monitor with LED back lighting, 262,144 colors
- Monitor dimensions: 5.98" x 3.58"
- Monitor resolution: 800 x 480 pixels

Capacitive keyboard

- 3 standard versions (Pay&Display / PayByPlate / PayBySpace)
- Customization on demand

## Payment

Coin selector

- Patented motor-driven coin selector: maximum 14 different types of coins or tokens (programmable)
- Automatic opening upon coin insertion
- Multi-criteria coins identification

Bank Note acceptor (option)

- Cashcode SM/MSM backload validator
- 4-way acceptance

Cashless version

Contact & contactless payment kits: smartcards & bank cards, EMV 2000, PCI-PED, UKCC, Mifare®, ISO 14443, NFC

## Collection

2 patented collection methods:

- Transfer - fixed cashbox with removable canister: 3.31 lb empty; approx. 48.5lb full / 5.8 l
- Rapide - exchangeable cashbox: 3.53 lb empty; approx. 43.21 lb full / 4.6 l
  - Bank Note Acceptor (option) - separate exchangeable cashbox & stacker
    - Coins: 6.03 lb empty; approx 24.91 lb full of 2,000 quarters / 3.5 l
    - Bill stacker: 1,000 bills

## Power supply

Solar or Mains

## Security

Money storage EN 14450 Level 2 certified

Attack detection

Additional shieldings and security enhancements

## Ticket

Thermal graphic printer - Horizontal or vertical printing - Text and logo - 203 dots per inch per line - 448 dots per column

Paper or self-adhesive tickets

- Without BNA option: standard format (w x l) 2.36" x 2.75" - capacity up to 6,500 tickets
- With BNA option: 4" minimum length - capacity up to 4,500 tickets

## Communications

3G modem, Ethernet

## Environment

More than 95% recyclable (ISO 22628) / European directives - RoHS and WEEE

## SECTION 32 14 13 - PRECAST CONCRETE UNIT PAVING

## PART 1 - GENERAL

## 1.01 REFERENCE

- A. Attention is directed to the printed form of the Contract, of the Parks and Recreation Department and Division 1 of which these specifications are hereby made a part.

## 1.02 SECTION INCLUDES

- A. Precast concrete unit paving including:
  - 1. All cutting to size and shape of unit pavers including cutting of all holes, slots and recesses required for anchors of all types.
  - 2. Edge restraints, setting bed and joint filler.
  - 3. All other items of masonry work shown or reasonably inferred to make the work of this Section complete.

## 1.03 RELATED WORK

- A. Section 31 10 00 – Site Clearing.
- B. Section 31 20 00 – Earth Moving.

## 1.04 QUALITY ASSURANCE

- A. Engage an installer who has successfully completed within the last 3 years at least 6 unit paver applications similar in type to that of this project and who will assign mechanics from these earlier applications to this project, of which one will serve as lead mechanic.
- B. Do not change source of brands for unit pavers or setting materials during progress of work.
- C. Construction Tolerances:
  - 1. Variations from plumb: 1/4 inch in 10 feet.
  - 2. Variations from level: 1/4 inch in 20 feet.
  - 3. Variations from slope as indicated for finished surface of paving: 1/4 inch in 10 feet.
  - 4. Variations from flush in unit to unit offset: 1/32 inch.
  - 5. Variations in joint width: 1/4 of joint width.
- D. Field Constructed Mock-Ups:
  - 1. Prior to selection of specific unit pavers provide samples of not less than 12 unit pavers of each type and color requested by Landscape Architect for selection of specific paver by Landscape Architect.

## 1.05 SUBMITTALS

- A. Manufacturer's catalog data and specification sheets for each type of manufactured product, including certification that each product complies with specified requirements. Include instructions for handling, storage, installation and protection.

B. Samples

1. Unit Pavers: each color, type and texture required. Include full range of exposed color and texture to be expected in the completed work.
2. Stonedust: One pound sample from at least 2 different sources.

1.06 PRODUCT DELIVERY, STORAGE AND HANDLING

- A. Handle and ship all items so as to prevent damage in transit. Use only material that is not subject to staining or discoloration for blocking and packing. Deliver materials to site in manufacturer's original containers with labels intact and seals unbroken.
- B. Unload and handle masonry units carefully so as to prevent chipping and breakage. Use pallets at time of unloading, storage and transporting to point of installation. Stack all unit pavers on timber platforms at least 6 inches above ground when stored on job site. Replace masonry materials damaged in any manner.
- C. Store and handle unit pavers to prevent their deterioration or damage due to moisture, temperature changes, contaminants, corrosion and other causes. Protect masonry units during storage and construction against moisture, soiling, staining and physical damage.
- D. Locate storage piles, stacks or bins to avoid and be protected from heavy and unnecessary traffic.

1.07 PROJECT CONDITIONS

- A. Protection of work: During erection, cover work with heavy waterproof sheeting at end of each day's work. Cover partially completed work when work is not in progress. Prevent grout or mortar from staining the face of masonry to be left exposed or painted. Immediately remove grout or mortar in contact with such masonry.
- B. Cleaning masonry: Comply with all Federal, and State Agency, industry and manufacturer recommended safety regulations and precautions. Protect and avoid contact to auto and pedestrian traffic.

1.08 WEATHER PROTECTION

- A. Comply with requirements of International Masonry All-Weather Council's "Guide Specification for Cold-Weather Masonry Construction". Heat materials and provide temporary protection of completed portions of masonry work.
- B. Do not erect any masonry when temperature of surrounding area is below 40 degrees F, or below 45 degrees F and falling, or forecast by public news media to fall to or below 35 degrees F within 24 hours.
- C. Do not lay paver units that are wet or frozen. Do not use frozen materials or materials mixed or coated with ice or frost. Do not build on frozen setting beds. Remove and replace unit paver work damaged by frost or freezing.
- D. Protect unit paver work in hot weather to prevent excessive evaporation of setting beds. Provide artificial shade, wind breaks and use cooled materials as required.

PART 2 - PRODUCTS

2.01 MATERIALS

A. UNIT PAVERS: Precast concrete of sizes, shapes, color, finish and absorption characteristics to match existing unit pavers. Pavers shall have a minimum compressive strength of 8,000 psi and a maximum absorption of 5% or less at 50 cycles of freeze thaw testing as per ASTM C67. Pavers are reported to be Hanover "Prest Brick", Tudor finish, Charcoal color in 4" x 8" x 2-3/8" and 8" x 8" x 2-3/8" nominal sizes as manufactured by Hanover Architectural Products, Hanover PA. Verify match prior to ordering.

1. The intent is to use pavers salvaged under Section 31 10 00 for part of this work provided they are whole, sound, intact and clean. Provide additional pavers to match as required.

B. EDGE RESTRAINTS: PVC of sizes, shapes, color and finish to match existing edge restraints. Edge restraints are reported to be "Pave Edge" Standard rigid style and flexible style as manufactured by Pave Tech, Inc., Prior Lake MN. Verify prior to ordering. Provide connectors and 10" long by 3/8" diameter galvanized steel anchor spikes.

C. STONEDUST SETTING BED AND JOINT FILLER: clean 100% crushed slag or stone, free of twigs, glass and other foreign materials, and dark grey in color. Gradation shall conform to the following requirements:

Sieve Size	% Passing by Weight
#4	100
#8	60-100
#100	0-15

Eighty percent (80%) by weight of the material retained on #10 sieve shall have at least one fractured face by artificial crushing.

1. Maximum liquid limit: L5.
2. Maximum plasticity index: 3.
3. Maximum abrasion loss by testing in conformance with AASHTO: 45%.

PART 3 - EXECUTION

3.01 INSTALLATION, GENERAL

A. Do not use unit pavers with chips, cracks, voids, discolorations or other defects that might be visible or cause staining in the finished work. Keep exposed surfaces free of mortar, bitumen and other deleterious substances at all times. No cracked, broken or chipped pavers will be allowed in the finished work.

B. Cut pavers as required with high speed masonry saw to provide clean, sharp edges and as required to fit neatly around all projections. Lay out coursing so that at end conditions no paver will have to be cut to a width of less than 2 inches. Cut as required to provide pattern shown and to fit adjoining work neatly. Place pavers in straight courses with hand tight joints in the pattern indicated on the Drawings and with uniform top surface and alignment. Protect newly laid pavers at all times from damage or stain.



- C. Install paver edge restraints in accordance with the drawings and manufacturers recommendations. Place restraints on top of compacted base. Spike rigid style edging using predrilled holes with a maximum spacing of 24" between spikes. Spike flexible style edging using predrilled holes with a maximum spacing of 12" between spikes. If holes in restraints do not meet spike placement requirements, Punch restraints and spike as required for anchoring. Connect sections of restraints with connectors. Bend to smooth radius as required. Provide corners and angles in continuous sections.

### 3.02 INSTALLATION OF UNIT PAVERS WITH STONE DUST SETTING BED

- A. Before commencing work, thoroughly clean surfaces to be covered with pavers of all dust, dirt and foreign matter. Place setting bed to depths indicated on the Drawings. Compact with mechanical tamper or by thoroughly flooding and drying setting bed twice.
- B. Set pavers on setting bed. Place pavers in straight courses with hand tight joints in the pattern indicated on the Drawings and with uniform top surface and alignment.
- C. Hand tight joints for unit pavers shall read from a minimum of 0 inches to a maximum of 1/16 inch. Sprinkle the surface of the pavers with a dry mixture of joint filler material and sweep into all joints so that no voids appear. Fog lightly with water and continue the sweeping operation until all joints are filled. Remove any stains that remain.

### 3.03 REPAIR

- A. Remove and replace unit pavers which are loose, chipped, broken, stained or otherwise damaged, or if units do not match adjoining units as intended. Provide new units to match adjoining units and install in same manner as original units, with same joint treatment to eliminate evidence of replacement.

### 3.04 CLEANING AND PROTECTION

- A. Promptly as work proceeds and upon completion, remove excess mortar, smears and droppings. Clean adjacent and adjoining surface of marks arising out of execution of work in this Section.
- B. Sweep up and remove daily sand, cleaning compounds and mixtures, dirt, debris and rubbish. Sweep or flush away nightly, all residual washed materials. Keep the premises neat and clean at all times.
- C. Clean soiled surfaces using a nonacidic solution that will not harm masonry or adjacent materials. Consult masonry manufacturer for acceptable cleaners. Do not use wire brushes, acid or other solutions that may cause discoloration. Use nonmetallic tools in cleaning operation. Apply in accordance with cleaner manufacturer recommendations.
- D. Protect masonry work in progress and after completion. Protect newly laid pavers at all times from damage or stain.

END OF SECTION

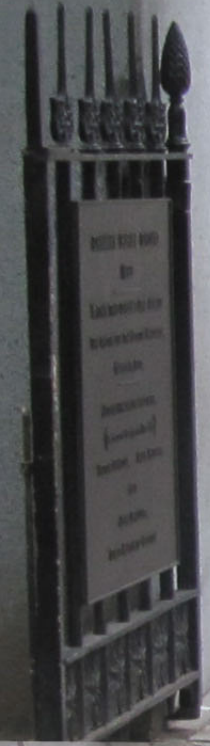



# CITY of BOSTON

## DONATION LEVELS

DIAMOND



**\$20.00**

PRESS

**1**

GOLD



**\$10.00**

PRESS

**2**

SILVER



**\$5.00**

PRESS

**3**

BRONZE



**\$1.00**

PRESS

**4**

PRESS **5** Amount of your choice, \$1-\$20

\$20.00

PRESS

1

\$10.00

PRESS

2

\$5.00

PRESS

3

\$1.00

PRESS

4

PRESS 5 Amount of your choice, \$1-\$20

START



2 3

5 6

8 9

0



0.9

Card Payment Keys



PRINT



CANCEL

CITY of BOSTON

03:07 PM

Insert card

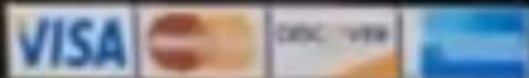

START



1 2 3

4 5 6

7 8 9

← 0 OK →

Card Payment Keys



PRINT



CANCEL

Credit

DONATION AMOUNT

**\$ 20.00**

**Approved**



CITY of BOSTON

03:07 PM



Please take your receipt

**THANK YOU!**

We appreciate your generous  
donation in the amount of:

**\$ 20.00**

Date/Time: 10/06/17 03:07 PM

