



260 Beacon 7th floor unit
existing window to be replaced
to match window of unit below

1.Existing Condition View of Rear Elevation



2.Existing Condition View of Rear Elevation



Hresko Associates,
Inc.
Architects
Landscape Architects
36 Bromfield Street
Boston, MA 02108
617-350-7666
eMail: hresko@ArchUSA.com

260 Beacon Street Rear Facade

7 June 2017

#29-18

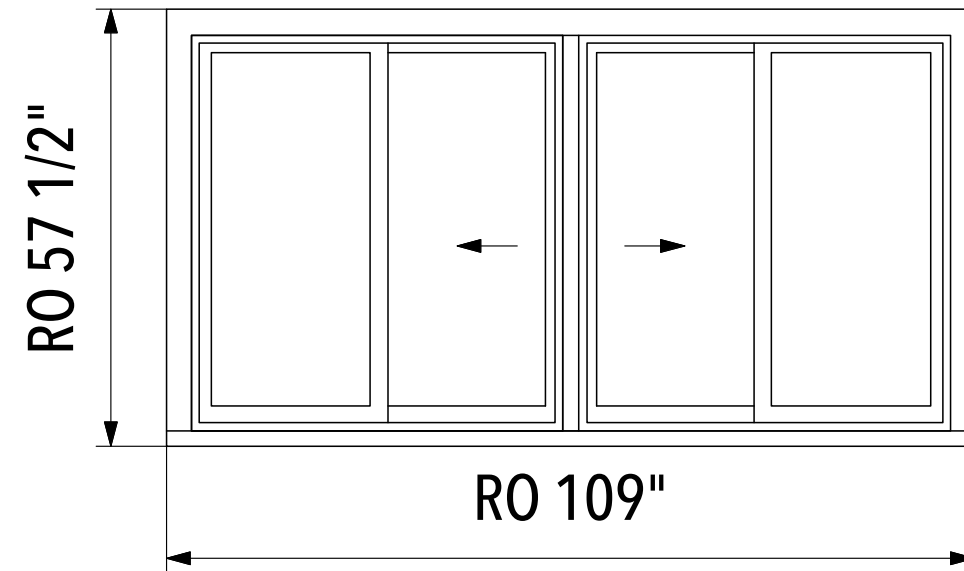

10 Existing window elevation

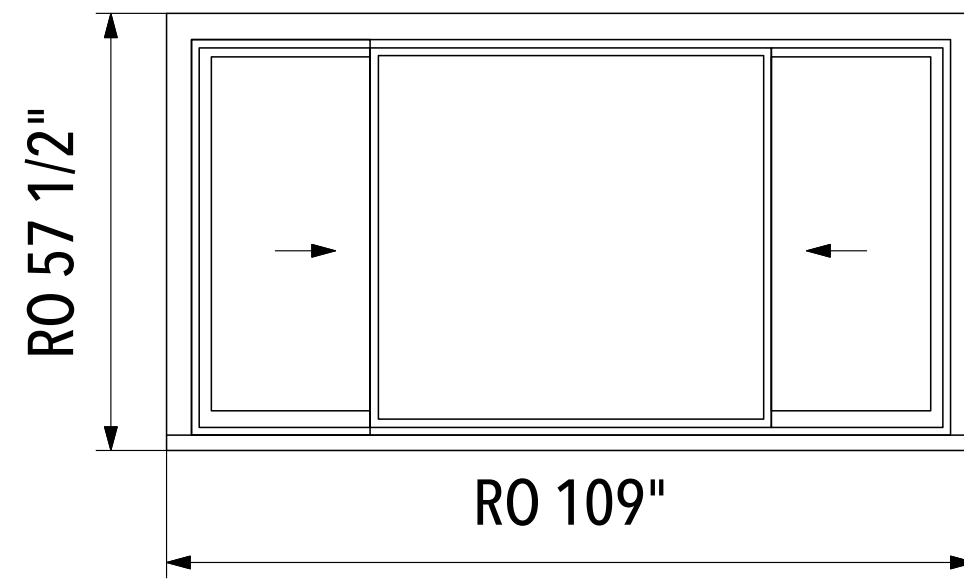

20 Proposed window elevation

Proposed Work



Photo1-Interior View of Existing Window

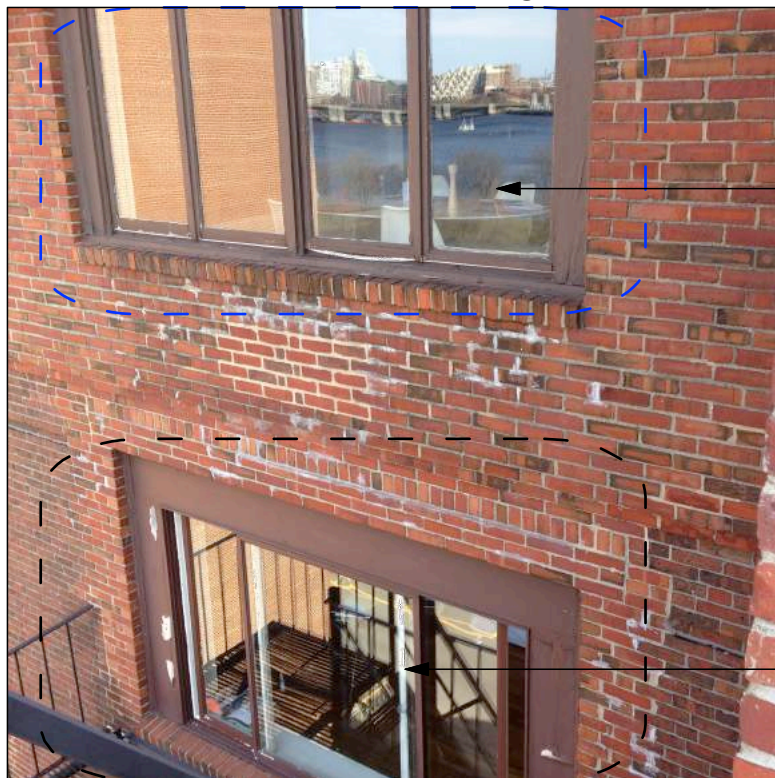

Photo2-Exterior View of Existing Windows -Rear Elevation

260 Beacon 7th floor unit
existing 4 light-window to be replaced
painted to match existing with a 3 light window
similar to the existing window of the floor below.
The window opening and all dimentions will remain the same.

260 Beacon 6th floor unit
existing window



Photo3-Rear Elevation Existing Condition



Photo4-Rear Elevation Existing Condition

Hresko Associates,
Inc.
Architects
Landscape Architects
36 Bromfield Street
Boston, MA 02108
617-350-7666
eMail: hresko@ArchUSA.com

260 Beacon Street Rear Facade

23 May 2017